

SANY[®]

SPECIFICATION



 220t

 75.5m

 107m

SAC2200C7

SANY ALL TERRAIN CRANE

QUALITY CHANGES THE WORLD

www.sanyglobal.com

V1.0

QUALITY CHANGES THE WORLD

It is one of the core business units in SANY Group, specializing in the development and manufacturing of high-end wheel cranes, crawler cranes and tower cranes, including the complete range of wheel cranes from 8 to 2400t, crawler cranes from 25 to 4500t and tower cranes from 6 to 185t.

三一集团旗下核心事业部，从事高端轮式起重机、履带起重机、塔式起重机系列产品的研发制造。覆盖8-2400吨全吨位轮式起重机，25-4500吨全吨位履带起重机，6-185吨塔式起重机。



SANY CRANE



SAC2200C7

SANY ALL TERRAIN CRANE 220 TON LIFTING CAPACITY

7-section 75.5m oval shaped boom and fixed jib 22m are standard, and the optional jib can be added up to 36m with two 7m inserts, delivering strong performance in lifting height, radius and weight.

70t full counterweight. 18t counterweight can be carried on board when traveling from jobsite to jobsite.

Chassis DF Cummins QSZ13-C525-30 engine / FAST transmission / Zhuzhou Gear Transfer case / HanDe axles (disc brake).

5-axle all-terrain carrier, H-type outriggers, hydro-pneumatic suspension, all-wheel steering, 6 steering modes, minimum steering radius of 10m.

Independent hydraulic systems for crane and chassis (independent hydraulic system for crane operation consisting of variable piston pump + slewing pump + auxiliary pump + fluid tank), better maneuverability.

Cable wiring for superstructure, IP67, easy maintenance with high reliability.

7节卵圆形主臂全伸75.5m，副臂标配22m，选配36m（含2节7m延伸节），吊高吊远吊重全能兼备。

70t配重，可带18t（前置+后置）配重随车短距离转场。

下车东康QSZ13-C525-30+法士特变速箱+株齿分动箱+汉德车桥（全碟刹）。

5桥全地面底盘，H形支腿，油气悬挂，全轮转向，6种转向模式，最小转弯半径10m。

上、下车独立液压系统（上车独立变量柱塞泵+回转泵+辅助泵+液压油箱液压系统），效率高、操控性好。

上车电缆布线，防护等级IP67，维护方便，可靠性更高。





Overall Dimensions

整机尺寸

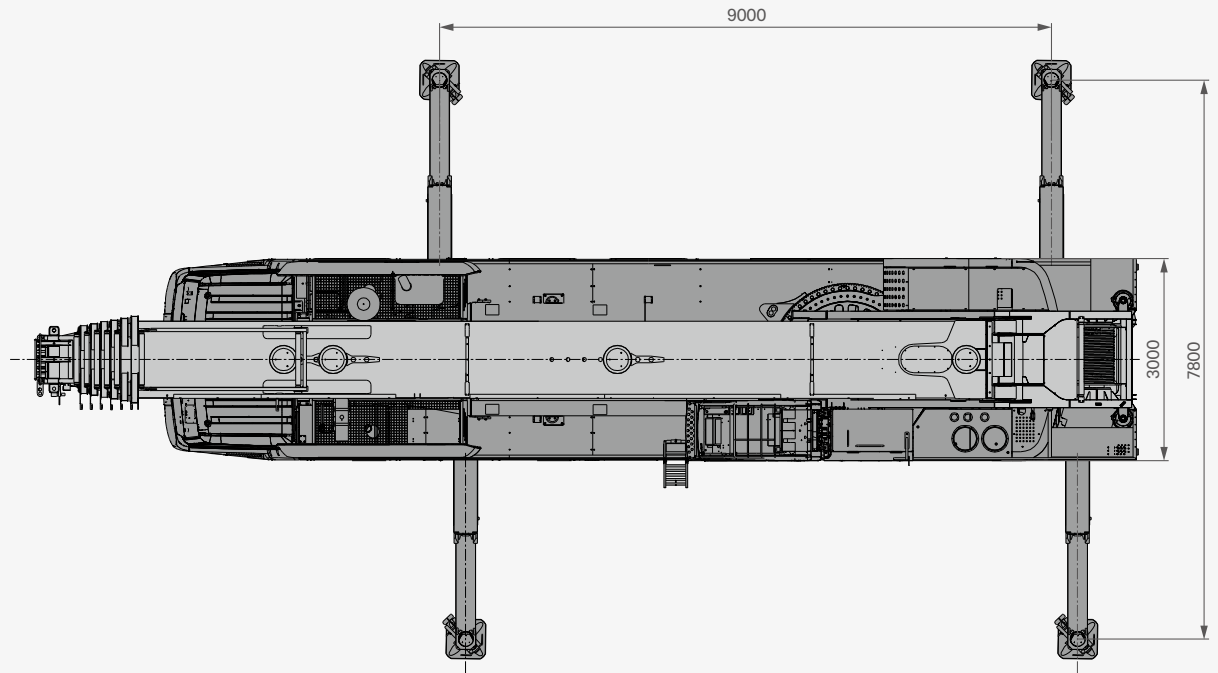
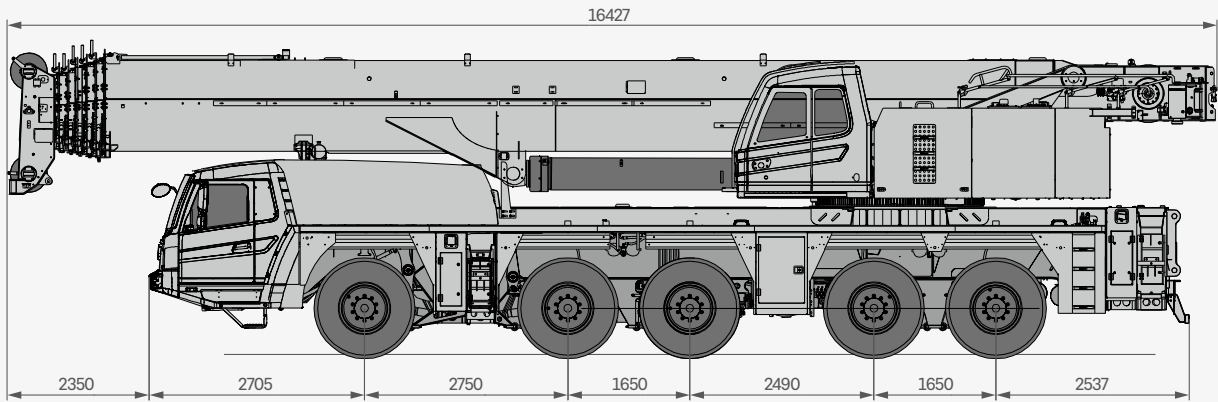

Technical Specification

整机参数

CATEGORY 类型	ITEM 项目	UNIT 单位	VALUE 参数	
CAPACITY 额定起重量	Max. lifting capacity 最大起重量	t	220	
WEIGHT 重量参数	Gross weight 整机总质量	kg	60000	
POWER (CHASSIS) 发动机参数 (下车)	Engine model 发动机型号 (排放标准)	-	QSZ13-C525-30 (EU Stage IIIA)	
	Max. engine power 发动机最大功率	kW/rpm	391/1900	
	Max. engine torque 发动机最大输出扭矩	N·m/rpm	2300/(1200-1700)	
POWER (SUPERSTRUCTURE) 发动机参数 (上车)	Engine model 发动机型号 (排放标准)	-	QSB6.7-C260 (EU Stage IIIA)	
	Max. engine power 发动机最大功率	kW/rpm	194/2200	
	Max. engine torque 发动机最大输出扭矩	N·m/rpm	990/1500	
DIMENSIONS 尺寸参数	Overall length 整机全长	mm	16427	
	Overall width 整机全宽	mm	3000	
	Overall height 整机全高	mm	4000	
TRAVEL 行驶参数	Max. travel speed 最高行驶速度	km/h	80	
	Steering radius 转弯半径	Min. steering radius 最小转弯半径	m	10
		Min. steering radius of boom tip 臂头最小转弯半径	m	13
	Wheel formula 车轮模式	-	10 × 8 × 10	
	Min. ground clearance 最小离地间隙	mm	270	
	Approach angle 接近角	°	16	
	Departure angle 离去角	°	12	
	Max. gradeability 最大爬坡度	-	45%	
	Fuel consumption per 100km 每 100 公里油耗	L	70	
	MAIN PERFORMANCE 主要性能参数	Working temperature range 使用温度区间	°C	-20~+40
Min. rated lifting radius 最小额定幅度		m	3	
Tail slewing radius 转台尾部回转半径		m	4.86	
Boom sections (Qty.) 臂节数		-	7	
Boom shape 臂形状		-	Oval shape 卵圆型	
Max. lifting moment 最大起重力矩		Basic boom 基本臂	kN·m	6664
		Full-extension boom 全伸主臂	kN·m	2744
Boom length 臂长		Basic boom 基本臂	m	14.1
		Full-extension boom 全伸主臂	m	75.5
		Max. combination of boom + jib 最长主臂 + 副臂	m	Standard 92.6 / optional 106.6 标配92.6/选配106.6
Max. lifting height 最大起重高度		Basic boom 基本臂	m	14.5
		Full-extension boom 全伸主臂	m	76
		Max. combination of boom + jib 最长主臂 + 副臂	m	Standard 93 / optional 107 标配93/选配107
Outrigger span (Longitudinal × Transverse) 支腿跨距 (纵 × 横)		m	9.0 × 7.8	
Jib offset 副臂安装角度		°	0, 20, 40	
AIRCONDITIONER 空调	In operator's cab 上车空调	-	Heating & Cooling 制冷、制热	
	In driver's cab 下车空调	-	Heating & Cooling 制冷、制热	

Technical Specification

整机参数



Axle Load 轴荷

Axle 轴	1	2	3	4	5	Gross weight 总重量
Axle load 轴荷 /t	≤12	≤12	≤12	≤12	≤12	≤60

Remark 备注:

some parts shall be removed to achieve axle load as above.

须拆除部分组件。



Hook 吊钩

Load 起重量 /t	Number of sheaves 滑轮数量	Rope rate 倍率	Hook weight/kg 吊钩重量
160 ○	9	19	2065
125 ○	7	15	1491
100 ○	5	11	1243
80 ●	3	7	693
32 ○	1	3	505
12.5 ●	0	1	270

● Standard 标配 ○ Optional 选配



Operations 主要动作参数

Item 项目	Max. single rope lifting speed (empty load) 单绳速度 (空载)	Rope diameter/length 钢丝绳直径 / 长度	Max. single line pull 最大单绳拉力
Main winch 主卷扬	130m/min	22mm/340m	10.5t
Auxiliary winch 副卷扬	130m/min	22mm/280m	10.5t
Slewing speed 回转速度	1.5r/min		
Full luffing up/down time of boom 主臂起落幅时间	60s/115s		
Full extension/retraction time of boom 主臂伸缩时间	660s/660s		
Outrigger jack 垂直支腿	Extension 伸	50s	
	Retraction 缩	50s	
Outrigger beam 水平支腿	Extension 伸	50s	
	Retraction 缩	50s	

Counterweight Combinations

配重组合

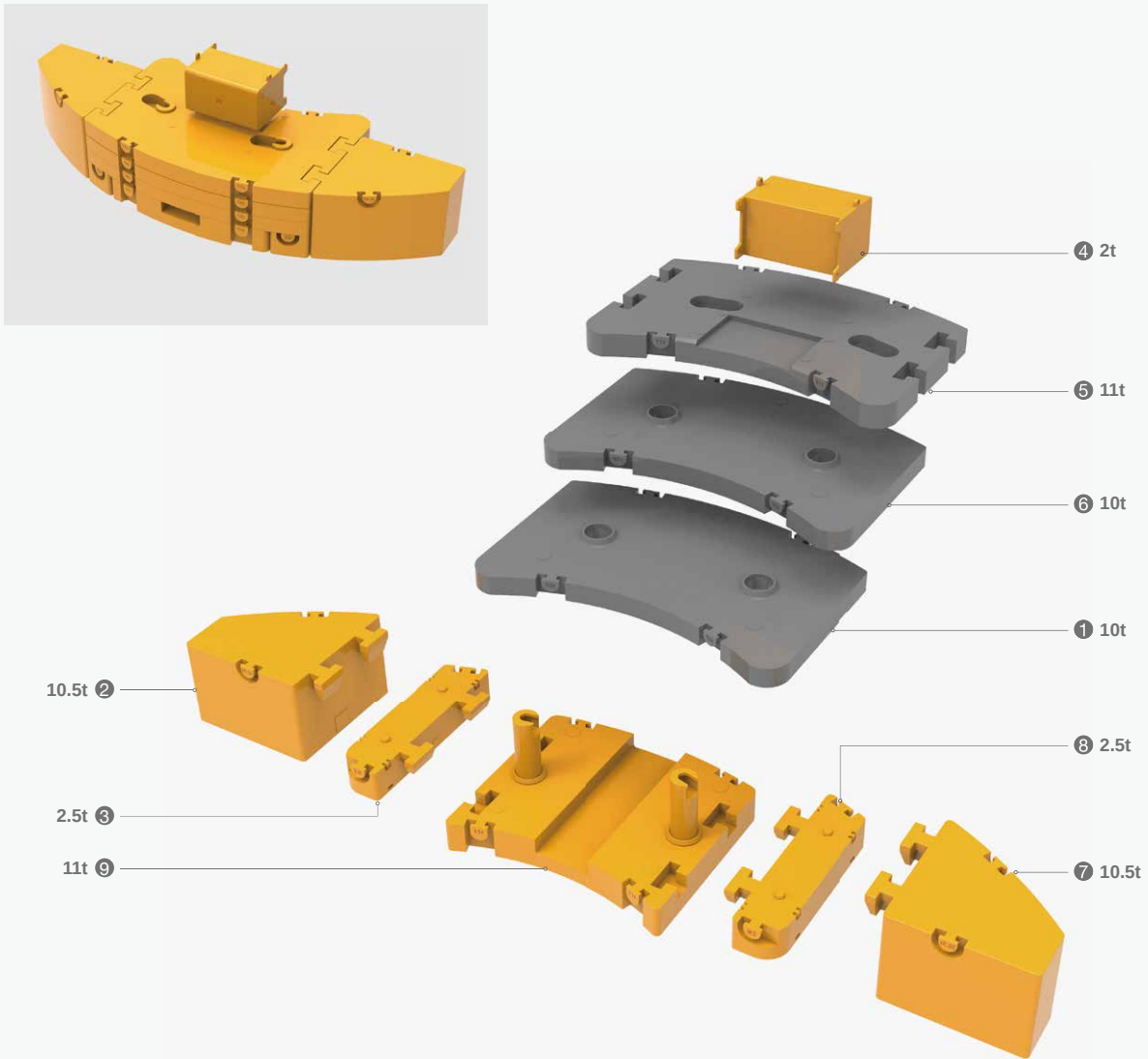

Total weight 总重量	① 10t	② 10.5t	③ 2.5t	④ 2t	⑤ 11t	⑥ 10t	⑦ 10.5t	⑧ 2.5t	⑨ 11t
0t									
11t									•
16t			•					•	•
18t			•	•				•	•
28t	•		•	•				•	•
38t	•		•	•		•		•	•
49t	•		•	•	•	•		•	•
70t	•	•	•	•	•	•	•	•	•

Transport Dimensions

运输尺寸

Unit:mm

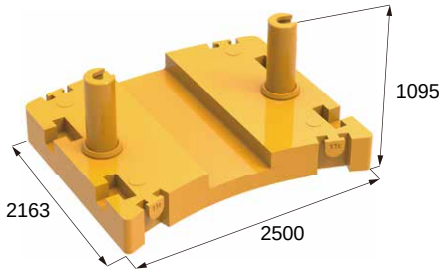

11t

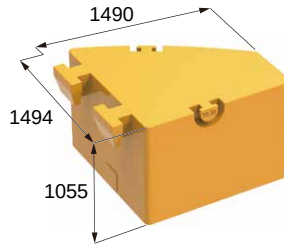

10.5t

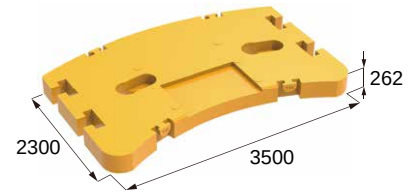

11t

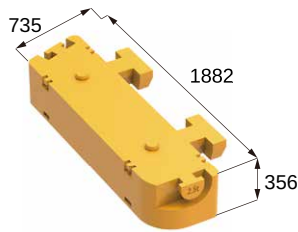

2.5t

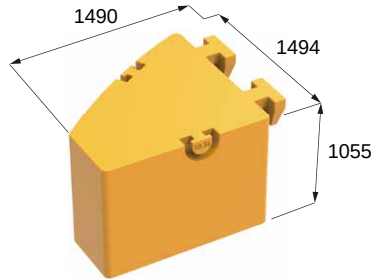

10.5t

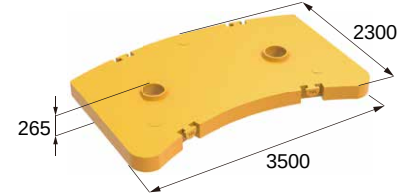

10t

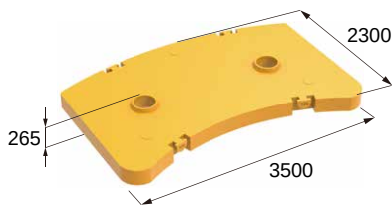

10t

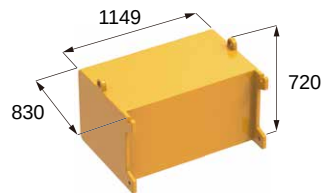

2t

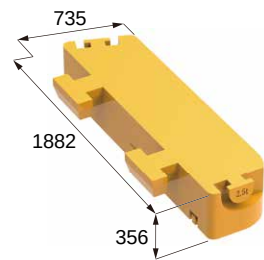

2.5t

Jobsite short distance transfer with 18t CW onboard
可带 18t 配重随车短距离转场

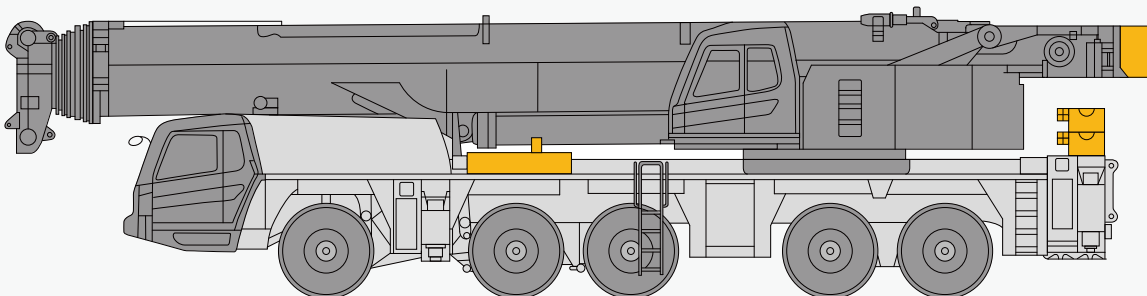

18t

Crane Introduction

整机介绍

Carrier 下车

Driver's cab 驾驶室

- Independently developed by Sany, it is of new steel structure, enabling high damping and sealing performance. It is configured with outward opening doors on both sides, air-suspension driver seat and passenger's seat, adjustable steering wheel, wide-angle rearview mirror, comfortable driver seat headrest, antifogging fan, HVAC, stereo radio, and a complete set of controls and instruments, creating a more comfortable, safe and user-friendly driving environment.
- 三一自主开发新型钢结构，减震性和封闭性优良，两侧外开式车门，配备气动悬置的驾驶室与副驾座、可调整式的转向盘、大视野后视镜、配有头枕的舒适驾驶椅、防雾扇、冷暖空调，立体收音机等装配，控制仪器和仪表齐全，更加舒适、安全、人性化。

Carrier frame 车架

- Designed and manufactured by Sany, it is a anti-torsion box structure welded by fine-grained high-strength steel plates with strong load-bearing capacity.
- 三一设计、制造，由细晶粒高强度钢板焊接而成的防扭转箱形结构，承载能力强。

Chassis engine 底盘发动机

- Model: DF Cummins QSZ13-C525-30, conforming to EU Stage IIIA emission standard.
- Output power: 391kW/1900rpm.
- Max. torque: 2300N·m/(1200-1700)rpm.
- Fuel reservoir capacity: 550L.
- 型号：东康 QSZ13-C525-30，EU Stage IIIA。
- 额定功率：391kW/1900rpm。
- 最大扭矩：2300N·m/(1200-1700)rpm。
- 燃油箱：550L。

Transmission 变速箱

- FAST transmission with hydraulic retarder, 12 speeds forward and 2 speeds reverse.
- 富士特变速箱，带液力缓速器，12个前进挡及2个倒挡。

Axle 车桥

- Hande axles are adopted, with all axles available for steering, and axles 1, 2, 4 and 5 for driving. Axles 1 and 2 are equipped with linkage-feedback hydraulic power steering system, and axles 3, 4 and 5 are equipped with electro-hydraulic steering system, providing steering control assist and several special steering modes for your option, and ensuring nimble steering and flexible control.
- 汉德车桥，全桥转向，1、2、4、5桥驱动。1、2桥采用杆系反馈的液压助力转向系统，3、4、5桥采用电液控制转向，可进行速度控制的辅助及可选择的特殊转向模式，转向轻便，操控灵活。

Drive & steer 驱动 / 转向

- 10 × 8 × 10.

Suspension system 悬挂系统

- All axles adopt height-adjustable hydro-pneumatic suspension with hydraulic lock. The suspension can be adjusted up by 140mm and down by 150mm, and has such modes including suspension, rigid locking, automatic leveling, vehicle lifting/lowering to adapt to various harsh working conditions and road surfaces, ensuring good NVH and lateral stability, and making the driving more comfortable.
- 全部车桥悬架装置均为高度可调带液压闭锁的油气悬架装置。具有悬挂、刚性锁定、自动调平、整车升降等模式，能适用各种恶劣工况和路面，保证车辆行驶的平顺性和侧稳定性，驾驶舒适。

Tires 轮胎

- 385/95R25 radial tires.
- 385/95R25 子午线真空胎。

Brake 制动系统

- Parking brake: The parking brake acts on axles 2-5 by the energy-stored spring.
- Service brake: All wheels adopt air servo brakes, forming a dual-circuit braking system. Disc brake is applied for all wheels.
- Assist brake: Transmission hydraulic retarder brake, which can reduce the wear of brake system and save the use costs.
- 驻车制动：由储能弹簧作用在第二到第五桥。
- 行车制动：所有轮子均用空气伺服制动器，双回路制动系统，所有车轮均装有盘式制动器。
- 辅助制动：变速箱液力缓速器制动，减少刹车部件的磨损，节约使用成本。

Steering 转向系统

- Servo power steering gear, dual-circuit hydraulic power steering system with emergency steering pump.
- 6 steering modes: 1) on-road steer (default); 2) all-wheel steer; 3) crab; 4) anti-yaw steer; 5) independent rear axle steer; 6) rear axle lock steer.
- 伺服动力转向器，双回路系统液压转向装置，带有应急转向泵。
- 转向模式共6种：1) 公路行驶模式(默认模式)；2) 全轮转向模式；3) 蟹形模式；4) 无偏摆转向模式；5) 独立后桥转向模式；6) 后桥锁定转向模式。

Outrigger 支腿

- H-shape outrigger layout with a longitudinal and transverse span of 9.0m × 7.8m and automatic leveling function is equipped, and they are extended and retracted hydraulically at both directions.
- H形支腿，纵、横跨距 9.0m × 7.8m，全液压水平垂直支腿油缸伸缩。具备自动水平调节功能。

Electrical system 电气系统

- Modern data bus system, 24V DC power supply, and 2 battery packs with a single capacity of 180AH are provided, allowing for power cutoff of chassis.
- The chassis adopts CAN bus system, multi-functional centralized display system with low power consumption, and LCD screen with contrast adjustable.
- 现代数据总线系统，24V 直流电源，2组蓄电池组，每组 180AH，可实现下车电源切断。
- 底盘采用 CAN 总线系统，多功能的集中显示系统，功率消耗小；采用 LCD 液晶显示，对比度可调整。

Crane Introduction

整机介绍

superstructure 上车

Operator's cab 操纵室

- 0°~20° tiltable, the operator's cab is made of corrosion-resistant steels, and designed with full-covering softened interior, panoramic sunroof, adjustable seat, etc. to make the operation more user-friendly, comfortable and easy. The LMI screen integrates the central console and operation display system and the operation data are well monitored.
- 0°~20° 可变角度, 采用耐腐蚀钢板, 配置全覆盖软化内饰、全景式天窗、可调式座椅等人性化设计, 操作更舒适、轻松; 配置力矩限制器显示屏, 实现主控台与操作显示系统有机结合, 使吊装作业的全部工况数据一目了然。

Superstructure engine 上车发动机

- Model: DF Cummins QSB6.7 194kW six-cylinder, water-cooled diesel engine, conforming to EU Stage IIIA emission standard.
- Fuel reservoir capacity: 285L.
- 型号: 东康 QSB6.7, 194kW, EU Stage IIIA, 六缸, 水冷却。
- 上车独立燃油箱: 285L。

Boom & telescoping system 臂架系统

- Boom: 7-section boom of oval shaped profile made of fine-grained high strength steel plate, with a full-extension length of 75.5m.
- Jib: 22m fixed jib is offered as standard, offsetable at 0°/20°/40°. Optional jib is up to 36m in total.
- Telescopic mechanism: The inter-independent hydraulic telescopic mechanism, more efficient, safe and reliable.
- 主臂: 7节臂, 主臂全伸长 75.5m, 由细晶粒高强度钢制成, 卵圆形截面。
- 副臂: 标配 22m, 选配 36m, 0°/20°/40° 机械变幅。
- 伸缩机构: 独立液压驱动伸缩, 高效安全可靠。

Hoist 起升系统

- The main winch adopts an electric proportional variable plunger motor, providing good hoisting micromobility and stability.
- 主卷扬采用电比例变量柱塞马达, 卷扬微动性、平稳性好。

Luffing system 变幅系统

- The passive luffing down system is more energy saving. The single cylinder plus front hinged support arrangement makes the luffing more effortless and improves the stressing condition of the boom; an electro proportionally controlled balance valve is adopted.
- 自重落幅, 更加节能。采用单根油缸, 前铰支布置, 变幅更省力且起重臂受力得到改善; 采用电比例控制平衡阀。

Control system 控制系统

- The crane is electronically controlled through the LMI system. Two multi-directional joysticks can return to the neutral position automatically. The movement of the crane is adjusted by regulating the hydraulic pump.
- 通过力矩限制器系统对起重机车进行电控, 两个多方向手柄, 可自动复位; 通过控制液压泵来控制上车的运动。

Counterweight 配重

- Combined counterweights are applied, totaling 70t. 18t counterweight can be carried on board when traveling from jobsite to jobsite. The counterweights can be self-loaded and unloaded via remote control.
- 组合式活动平衡重 70t, 可带 18t (前置 + 后置配重) 随车短距离转场, 无线遥控实现配重起落。

Slewing platform 转台结构

- Independently designed by Sany, it is made of fine-grained high-strength steel plates, with optimized structure.
- 三一自主设计, 结构更优化, 由细晶粒高强度钢制成。

Slewing 回转系统

- The slewing system adopts variable piston pump, and supports 360° rotation at a speed of 0~1.5r/min. The electro proportional closed type hydraulic circuit and electro proportional pedals are applied.
- 变量柱塞主油泵, 360° 回转, 回转速度 0~1.5r/min; 采用电比例闭式液压回路, 电比例踏板。

Hydraulics 液压系统

- Key hydraulic components including main pump, slewing pump, main valve, winch motor and balance valve are of high quality, ensuring the stability and reliability of the hydraulic system; the accurate parameter matching further improves the operation performance.
- Electro proportional variable displacement piston pump is applied, and the pump displacement is adjusted in real-time by changing the opening of electric control joy, realizing high-precision flow control and reducing the energy consumption.
- Self-developed dual-pump shunt/confluence main valve enables higher speed in case of single motion and better maneuverability in case of combined motions.
- Passive compensated luffing down is adopted, ensuring better inching movement and stability.
- The slewing system is of closed type, and the flow rate and the flowing direction are changed by adjusting the variable pump swash plate, providing better inching mobility and stability. Single-cylinder pin telescoping system is applied for the boom.
- 采用高品质的主油泵、回转泵、主阀、卷扬马达、平衡等关键液压元件, 保证液压系统稳定、可靠; 通过精确的参数匹配, 使操作性能更加优越。
- 采用电比例变量柱塞泵, 通过电控手柄开度的变化, 实时调节油泵排量, 实现高精度流量控制, 作业时无能量损耗。
- 采用自主研发的双泵合/分流主阀, 单动作双泵合流效率更高, 组合动作双泵分流操控性更好。
- 采用自重落幅补偿液压系统, 落幅微动性、平稳性更优越。
- 回转为闭式系统, 通过调节变量泵斜盘的角度来改变流量及方向, 微动性优越、回转平稳。主臂伸缩采用单缸插销伸缩系统。

Safety equipment 安全装置

- Moment limiter: The moment limiter calculation system is developed by using the mechanics analysis method based on the hoisting mechanical model, and the rated hoisting accuracy is controlled within $\pm 5\%$ through online no-load calibration, enabling all-round protection for the hoisting operations; in case of overloading operations, the system will send an alarm automatically to provide safety guarantee for operations.
- Hydraulic balance valve, overflow valve, two-way hydraulic lock and other elements provided for the hydraulic system, ensuring good stability and reliability of the hydraulic system.
- 3rd wrap indicator of main winch to prevent rollover of wire rope.
- A2B limit switch mounted at tip of boom and jib to prevent over-hoisting of the wire rope.
- Anemometer mounted at tip of boom to check if the wind speed is out of the allowable operating range of the crane.
- 力矩限制器: 采用分析力学方法, 建立了基于吊重力学模型的力矩限制器计算系统, 通过在线空载标定, 额定吊重精度达到 $\pm 5\%$, 全方位保护吊载作业; 超载作业时, 系统自动报警提示, 为操纵作业提供安全保障。
- 液压系统配置液压平衡阀、溢流阀、双向液压锁等元件, 实现液压系统稳定可靠。
- 卷扬配置三圈保护器, 防止钢丝绳过放。
- 主副臂臂端配置高度限位器, 防止钢丝绳过卷。
- 臂端装有风速仪, 检测高空风速是否超过可作业允许范围。

Operating Range - Telescopic Boom

起升高度曲线 - 主臂

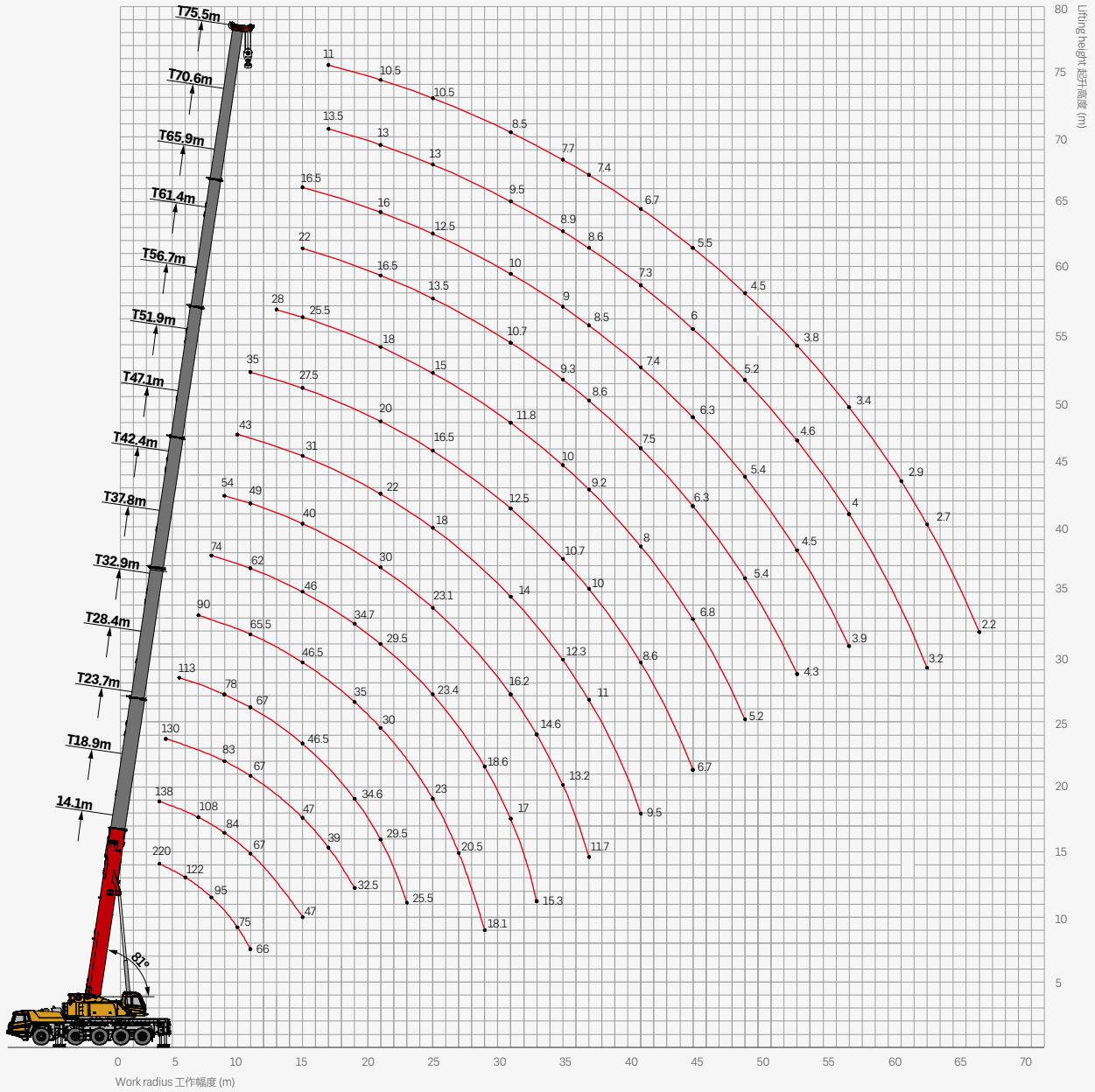

Load Chart - Telescopic Boom

性能表 - 主臂

Unit: t



	14.1	18.9	23.7	28.4	33.2	37.8	42.4	47.1	51.9	56.7	61.4	66.1	70.6	75.5	
3	220*	138													3
3.5	145	136	130												3.5
4	136	130	130												4
4.5	129	127	125	113											4.5
5	122	120	116	105											5
6	109	108	103	95	90										6
7	95	94	92	86	85	74									7
8	85	84	83	78	79	71	54								8
9	75	75	74	72	72	67	52	43							9
10	66	67	67	67	65.5	62	49	40	35						10
12		54.5	55.5	54	55	54.5	44	35	32	28					12
14		47	47	46.5	46.5	46	40	31	27.5	25.5	22	16.5			14
16			39	40	40	41	36.5	27.5	24.5	23.5	21	16.5	13.5	11	16
18				32.5	34.6	35	34.7	33	25	22	21	19	16.5	13	18
20					29.5	30	29.5	30	22	20	18	16.5	16	13	20
22						25.5	26.5	25.5	26.4	20	18	16.6	14.5	13.5	22
24							23	23.4	23.1	18	16.5	15	13.5	12.5	24
26								20.5	20.8	20.4	16.5	15	13.8	12.5	26
28									18.1	18.6	18.2	15	13.5	12.8	28
30										17	16.2	14	12.5	11.8	30
32											15.3	14.6	13	11.5	32
34												13.2	12.3	10.7	34
36													11.7	11	36
38														10	38
40															40
42															42
44															44
46															46
48															48
50															50
52															52
54															54
56															56
58															58
60															60
62															62
64															64
66															66
	14	14	12	12	10	8	6	5	4	4	3	3	3	2	

Remark

Column marked by * indicates load over rear with additional sheaves required.

* 号列: 正后方吊载, 须安装辅助装置

Operating Range - Fixed Jib

起升高度曲线 - 副臂

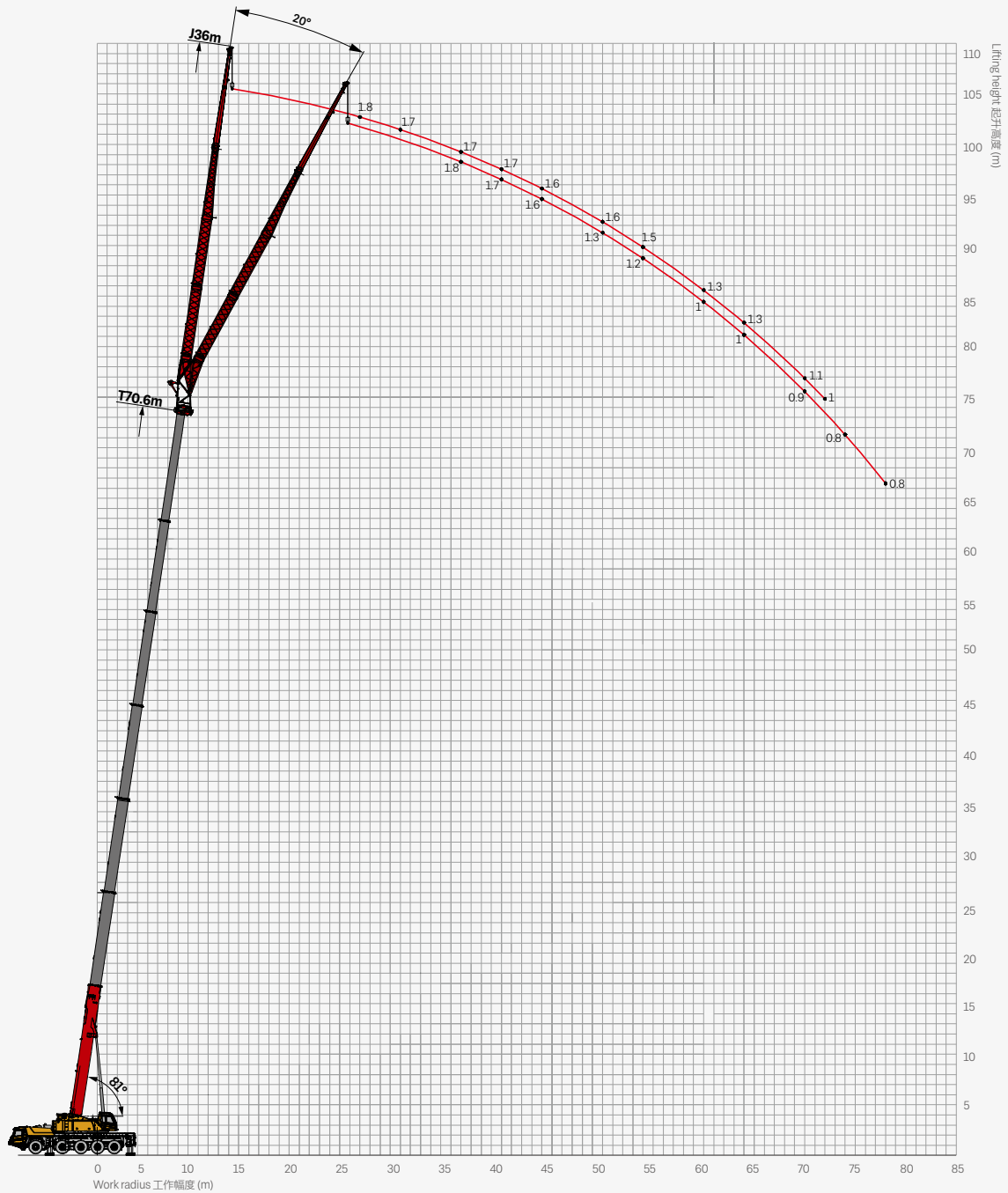

Load Chart - Fixed Jib

性能表 - 副臂

Unit: t

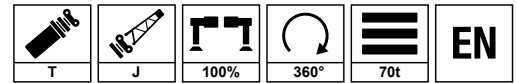

m 100kg	61.4m+36m		66.1m+36m		70.6m+36m		m 100kg
	0°	20°	0°	20°	0°	20°	
20	2.2		2.1				20
22	2.2		2				22
24	2.2		2		1.8		24
26	2.1		2		1.8		26
28	2.1	2	2		1.8		28
30	2	2	1.9		1.7		30
32	2	1.9	1.9		1.7		32
34	2	1.9	1.9	1.9	1.7		34
36	1.9	1.8	1.8	1.8	1.7	1.8	36
38	1.9	1.8	1.8	1.8	1.7	1.8	38
40	1.8	1.7	1.8	1.7	1.7	1.7	40
42	1.8	1.7	1.7	1.7	1.7	1.6	42
44	1.7	1.6	1.7	1.6	1.6	1.6	44
46	1.7	1.6	1.7	1.5	1.6	1.5	46
48	1.7	1.5	1.6	1.5	1.6	1.4	48
50	1.6	1.5	1.6	1.4	1.6	1.3	50
52	1.6	1.4	1.6	1.3	1.6	1.3	52
54	1.5	1.3	1.5	1.3	1.5	1.2	54
56	1.5	1.3	1.5	1.2	1.4	1.1	56
58	1.4	1.3	1.4	1.1	1.4	1	58
60	1.4	1.2	1.3	1.1	1.3	1	60
62	1.3	1.2	1.3	1	1.3	1	62
64	1.3	1.1	1.2	1	1.2	1	64
66	1.3	1.1	1.2	1	1.2	0.9	66
68	1.2	1.1	1.1	1	1.1	0.9	68
70	1.1	1	1.1	0.9	1.1	0.9	70
72		1	0.9	0.9	1	0.9	72
74		0.9		0.9		0.8	74
76				0.9		0.8	76
78						0.8	78
80							80
⚡	1	1	1	1	1	1	⚡



SANY GROUP CRANE BU

SANY Mobile Crane Industrial Park, No.168 Jinzhou Avenue, Jinzhou Development Zone, Changsha City,
Hunan Province, P.R. China Zip 410600
Consulting sanycrane@sanygroup.com (Crane BU) / crd@sany.com.cn (IHQ)
After-sales Service 0086-400 6098 318

Reminder:

Any change in the technical parameters and configuration due to product modification or upgrade may occur without prior notice.
The machine in the picture may include additional equipment. This brochure is for reference only, and goods in kind shall prevail.
Copyright at SANY. No part of this brochure may be copied or used for any purpose without written approval from SANY.

© Edited in July 2023

三一集团起重事业部

中国湖南长沙金洲开发区金洲大道 168 号 三一汽车起重机产业园 邮编: 410600
咨询: sanycrane@sanygroup.com (起重事业部) / crd@sany.com.cn (国际总部)
海外售后服务: 0086-400 6098 318

温馨提示:

由于技术不断更新, 技术参数及配置如有更改, 恕不另行通知。图中机器可能包括附加设备, 本画册仅供参考, 以实物为准。
版权为三一所有, 未经三一书面许可, 本画册任何内容不得被复制用于任何目的。

© 2023 年 7 月版

