

SANY[®]

SPECIFICATION



 **600t**

 **90.1m**

 **126m**

SAC6000T7-8

SANY ALL TERRAIN CRANE

QUALITY CHANGES THE WORLD

www.sanyglobal.com

V1.1

It is one of the core business units in SANY Group, specializing in the development and manufacturing of high-end wheel cranes, crawler cranes and tower cranes, including the complete range of wheel cranes from 8 to 2400t, crawler cranes from 25 to 4500t and tower cranes from 6 to 185t.

三一集团旗下核心事业部，从事高端轮式起重机、履带起重机、塔式起重机系列产品的研发制造。覆盖8-2400吨全吨位轮式起重机，25-4500吨全吨位履带起重机，6-185吨塔式起重机。



SANY CRANE



Strong lifting capacity

Main boom – 7 section U shape profile, full-extension boom 90.1m.
Fixed jib – variable lengths from 8m to 48m, offsetable at 0°/20°/40°, max. lifting height 126m.
Superlift device – Self assembly and disassembly, lifting capacities more than doubled at long boom.
Wind power configuration – 47m wind power jib, covering 100m hub height wind turbine maintenance.

起重性能强

主起重臂:七节U型主臂,全伸臂90.1m。
固定副臂:8m-48m,多种臂长组合,0°/20°/40°可变位,最大起升高度126m。
超起装置:不用辅助吊车可实现自拆装,长臂段起重性能增加一倍以上。
风电专用工况:最长47m风电臂,覆盖100m中心高度及以下风机部件检修运维。

Excellent driving performance

Innovative 7-axle chassis, all-wheel steering and 4-axle drive, and a variety of steering and drive modes bring enhanced driving flexibility. The new intelligent multi-mode hydro-pneumatic suspension functions real-time vehicle attitude monitoring, active lifting and variable damping adaptation, etc., making driving more comfortable and stable.
With a strong power and transmission system equipped with hydraulic torque converter and hydraulic retarder, the driving safety and smoothness are greatly improved.
Equipped with 505 large tires, the transportation speed significantly increases. During transportation with boom and outriggers, there is no speed limit. With the super lifting device.

行驶性能卓越

创新七桥加强型底盘结构,全轮转向、四桥驱动,多种转向及驱动模式,行驶适应能力超强。全新智能多模式油气悬挂系统,车体姿态实时监控、主动提升和变阻尼自适应等功能,驾乘更舒适,行驶更稳定。
强劲动力及传动系统,配备液力变矩、缓速制动,极大提高行驶安全性和平顺性。
配置505大轮胎,转场速度大幅提高,带臂带支腿转场不限速。

**SANY ALL TERRAIN CRANE
SAC6000T7-8 / 600T LIFTING CAPACITY**

High efficiency and reliability

Multi-pump and multi-circuit hydraulic system, electric proportional and multi-level pressure control to realize speed grading and inching mobility, achieving better performance.

The new superlift stable tensioning control technology, one click auto tensioning and swing away/back, improves the operation efficiency by 20% and the lifting performance of medium and long boom by 5%-10%.

Less operational constraints thanks to three outrigger span combinations, more suitable for working in constricted areas.

高效可靠

多泵、多回路液压系统,电比例及多级压力控制,实现速度分档和微动性优化,性能更卓越。全新定长张紧控制技术,一键自动张紧及收/展超起,作业效率提升20%,中长臂段起重性能提升5%-10%。

作业限制小,三支腿跨度组合,全方位适配狭窄场地需求。

High level safety

The multifunctional wireless remote control system improves operation ease and safety.

The anti-tipping early-warning system, the safety protection program and fault diagnosis system further enhances safety.

The load moment indicator system with high precision, high stability and high intelligence is adopted to protect the lifting operation in an all-round way.

Equipped with adequate sensors for timely data feedback, real-time monitoring, the operator has access to the working data at any time.

安全可靠

多功能无线遥控系统,起重机作业更加方便,操作更加安全。

配备防倾翻预警系统,操作安全保护程序及故障诊断系统,保证车辆的作业安全。

采用高精度、高稳定性、高智能化的力矩限制器系统,全方位保护吊载作业。

配置丰富的传感器件,及时反馈数据信息,实时监控,随时掌握整车工作状态。



Overall Dimensions

整机尺寸

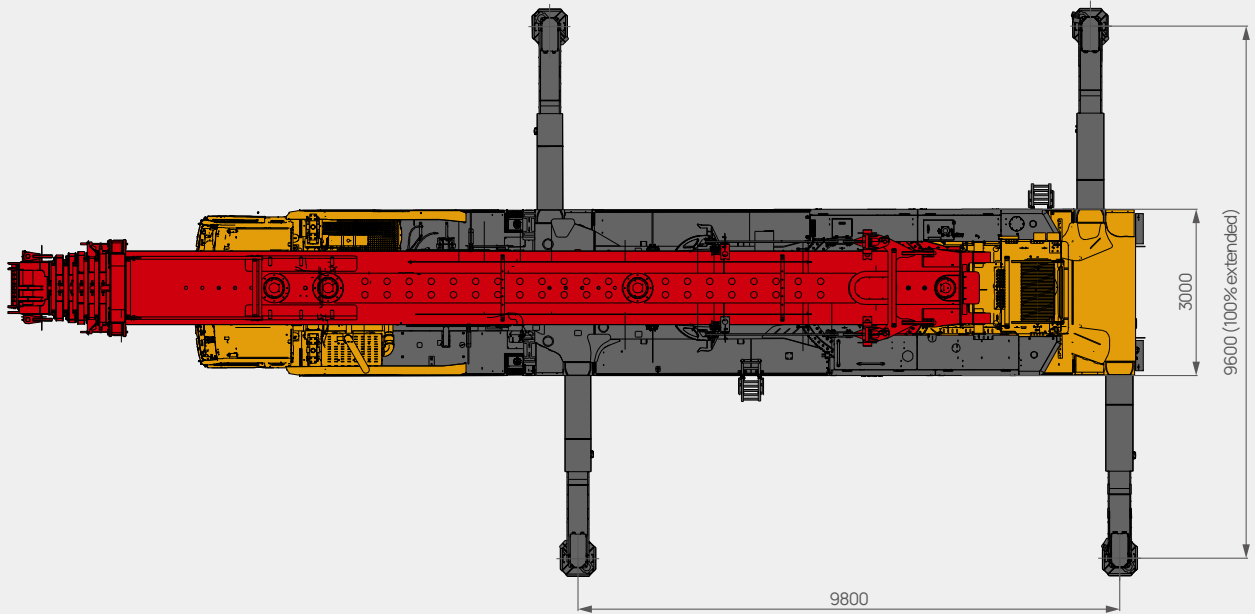
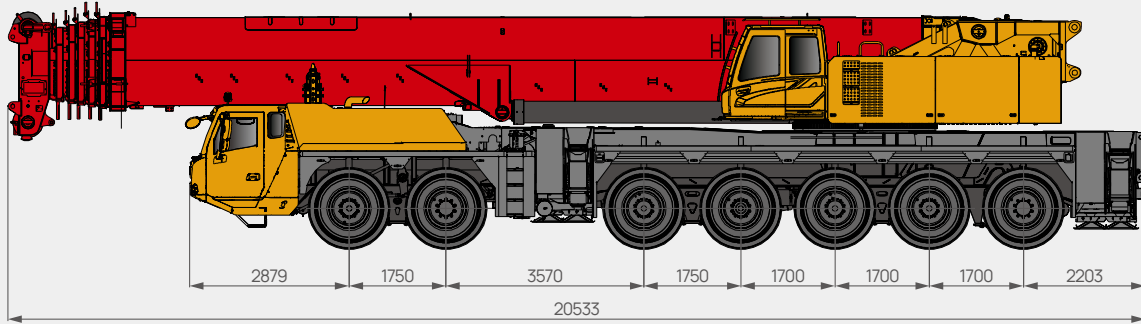

Technical Specification

整机参数

CATEGORY 类型	ITEM 项目	UNIT 单位	VALUE 参数	
CAPACITY 额定起重量	Max. lifting capacity 最大起重量	t	600	
WEIGHT 重量	Gross weight 整机总质量	kg	84000 (boom section 3-7 and wire rope and hook removed 拆除3-7节臂, 钢丝绳及吊钩等附件)	
POWER CHASSIS 发动机参数(下车)	Engine model 发动机型号 (排放标准)	-	WP15H660E61	
	Max. engine power 发动机最大功率	kW/rpm	485/1800	
	Max. engine torque 发动机最大输出扭矩	N·m/rpm	3200/(900~1400)	
POWER SUPERSTRUCTURE 发动机参数(上车)	Engine model 发动机型号 (排放标准)	-	WP7G300E473	
	Max. engine power 发动机最大功率	kW/rpm	221/2200	
	Max. engine torque 发动机最大输出扭矩	N·m/rpm	1200/(1400~1600)	
DIMENSIONS 尺寸参数	Overall length 整机全长	mm	19050 (boom section 3-7 and wire rope and hook removed 拆除3-7节臂, 钢丝绳及吊钩等附件)	
	Overall width 整机全宽	mm	3000	
	Overall height 整机全高	mm	4000	
TRAVEL 行驶参数	Max. travel speed 最高行驶速度	km/h	70	
	Steering radius 转弯半径	Min. steering radius 最小转弯半径	m	13
		Min. steering radius of boom tip 臂头最小转弯半径	m	15.4
	Wheel formula 车轮模式	-	14 × 8	
	Min. ground clearance 最小离地间隙	mm	340	
	Approach angle 接近角	°	14	
	Departure angle 离去角	°	12	
	Max. gradeability 最大爬坡度	-	45%	
	Fuel consumption per 100km 每100公里油耗	L	≤112	
	MAIN PERFORMANCE 主要性能参数	Working temperature range 使用温度区间	°C	-20~+40
Min. rated lifting radius 最小额定幅度		m	3	
Tail slewing radius 转台尾部回转半径		m	6.3	
Boom sections (Qty.) 臂节数		-	7	
Boom shape 臂形状		-	U shape U型	
Max. lifting moment 最大起重力矩		Basic boom 基本臂	kN·m	18000 (Rearward lifting 正后方)
		Full-extension boom 全伸主臂	kN·m	8480
		Full-extension boom + jib 全伸主臂 + 副臂	kN·m	2736
Boom length 臂长		Basic boom 基本臂	m	17.2
		Full-extension boom 全伸主臂	m	90.1
		Full-extension boom + jib 全伸主臂 + 副臂	m	126.6
Max. lifting height 最大起重高度		Basic boom 基本臂	m	17.2
		Full-extension boom 全伸主臂	m	90
		Full-extension boom + jib 全伸主臂 + 副臂	m	126
Outrigger span (Longitudinal × Transverse) 支腿跨距 (纵 × 横)	m	9.8 × 9.6		
Jib offset 副臂安装角度	°	0, 20, 40		
AIRCONDITIONER 空调	In operator's cab 上车空调	-	Heating & Cooling 制冷、制热	
	In driver's cab 下车空调	-	Heating & Cooling 制冷、制热	

Technical Specification

整机参数



Axle Load 轴荷

Axle 轴	1	2	3	4	5	6	7	Gross weight 总重量
Axle load 轴荷 /t	12	12	12	12	12	12	12	84
Remark 备注	Boom section 3-7 and wire rope and hook removed. 拆除3-7节臂,钢丝绳及吊钩等附件。							



Hook 吊钩

Rated load 额载 /t	Number of sheaves 滑轮数量	Rope rate 倍率	Hook weight/kg 吊钩重量
200 ○	9	19	2440
160 ●	7	15	1839
80 ●	3	7	679
32 ○	1	3	505
12.5 ○	0	1	266

● Standard 标配 ○ Optional 选配



Operations 主要动作参数

Item 项目	Max.single rope lifting speed (empty load) 单绳速度 (空载)	Rope diameter/length 钢丝绳直径 / 长度	Max. single line pull 最大单绳拉力
Main winch 主卷扬	130m/min	24mm / 605m	12.5kN
Slewing speed 回转速度	1.2r/min		
Full luffing up/down time of boom 主臂起落幅时间	95s/150s		
Full extension time of boom 主臂全伸时间	1000s/1000s		
Outrigger beam 水平支腿	Extension 伸	50s	
	Retraction 缩	50s	
Outrigger jack 垂直支腿	Extension 伸	50s	
	Retraction 缩	50s	

Crane Introduction

整机介绍

Carrier 下车

Driver's cab 驾驶室

- The cab is a new type of steel structure independently developed by SANY, with excellent shock absorption and sealing performance. With outward opening doors on both sides, the cab is equipped with driver's seat and passenger's seat with pneumatic suspension, adjustable steering wheel, large-field rearview mirrors, comfortable driver's seat with headrest, anti-fog fan, heating and cooling A/C, and stereo radio, etc., as well as complete control instruments and meters, so that the driving will be more comfortable, safer, and more user-friendly.
- 三一自主研发新款驾驶室, 自主研发新型钢结构, 减震性和封闭性优良, 两侧外开式车门, 配备气动悬置的驾驶室与副驾驶室、可调整式的转向盘、大视野后视镜、配有头枕的舒适驾驶椅、防雾扇、冷暖空调、立体收音机等装配, 控制仪器和仪表齐全, 更加舒适、安全、人性化。

Carrier frame 车架

- Designed and manufactured by SANY, the torsion-resistant box-type structure with optimized structure and low weight is welded by fine-grained high-strength steel plates. The outriggers are retracted in special fixed boxes, which are located between axle 2 and axle 3 and at the carrier frame tail, and equipped with front and rear towing devices.
- 三一自主研发并专业化制造, 结构优化, 防扭转箱型结构, 细晶粒高强度钢板焊接制作; 支腿收缩在特制固定箱中, 支腿箱位于2桥和3桥之间以及车架尾部; 并且配备前后牵引挂钩。

Chassis engine 底盘发动机

- Type: Electronically controlled, in-line 6-cylinder, watercooled, supercharged, intercooled diesel engine.
- Power: 485kW/1800rpm.
- Torque: 3200N·m/(900~1400)rpm.
- Fuel reservoir capacity: approx. 540L.
- 型式: 电控、直列六缸、水冷却、增压中冷、电喷、柴油发动机。
- 输出功率: 485kW/1800rpm。
- 最大扭矩: 3200N·m/(900-1400)rpm。
- 燃料箱容量: 约540L。

Transmission 变速箱

- ZF auto transmission, with integral hydraulic retarder for wear-free brake, features a wide range of speed ratio with 12 forward speeds and 2 reversing speeds, which is adaptable to slope climbing and high-speed traveling on public roads.
- 德国ZF原装进口变速箱, 速比范围大(12个前进档、2个倒挡), 智能自适应换档, 一体式液力缓速器无磨损制动, 液力变矩无磨损起动, 极致爬坡脱困能力, 既可满足低速场地爬坡又可满足公路高速行驶。

Axle 车桥

- High quality heavy-duty axles, with all axles steered, and axles 1, 3, 5, 6 are driven. Axles 1, 2 adopt hydraulic power steering system with linkage feedback, and axles 3-6 adopt electrohydraulic control steering, with assist for speed control and selectable special steering mode, for easy steering and flexible operation.
- 高品质车桥, 全桥转向, 1、3、5、6桥驱动。1、2桥采用杆系反馈的液助力转向系统, 3、4、5、6、7桥采用电液控制转向, 可进行速度控制的辅助及可选择特殊转向模式, 转向轻便, 操控灵活。

Suspension system 悬挂系统

- Multi-mode height adjustable (+120mm/-130mm) hydro-pneumatic suspension devices with hydraulic lockout, which can realize five modes incl. suspension, rigid locking, auto leveling, whole vehicle rising and single point rising & lowering. It can conduct real-time monitoring of vehicle attitude, smart identifying of axle load, active rising and self-adaptability to tough terrains, ensuring smoothness and lateral stability during driving.
- 智能多模式油气悬挂系统, 悬架高度可调, 带液压闭锁装置, 能实现悬挂、刚性锁定、自动调平、整车升降、单点升降五种模式。具备车体姿态实时监控、轴荷智能识别、主动提升和复杂路面自适应等功能, 驾乘更舒适, 行驶更稳定。

Steering 转向系统

- All new constant pressure and constant flow steering system featuring linear following without lag and precise steering angle. Three steering emergency systems available. The steering mode is adjusted according to the speed. Starting from 30km/h, axle 3 and 4 stop steering, and by 60km/h, axle 5 and 6 stop steering.
- Six steering modes: 1) on-road driving (default); 2) all wheel steering; 3) crab steering; 4) reduced swing out steering; 5) independent rear axle steering; 6) independent front axle steering.
- 全新的恒压恒流量智能转向系统, 线性跟随无滞后, 转角精准零偏差; 三重转向应急系统, 行驶更加安全可靠。
- 可分为六种转向模式: 1) 公路行驶模式(默认模式); 2) 全转向模式; 3) 蟹形模式; 4) 无偏摆转向模式; 5) 独立后桥转向模式; 6) 后桥锁定转向模式。

Tires 轮胎

- 14 heavy duty big tires.
- Tire pressure monitoring system is configured to monitor tire pressure and temperature in real time during driving, and provide alarm tips to improve driving safety.
- 14个重载大轮胎。
- 配置胎压监测系统, 行驶过程中实时监测轮胎压力与温度, 并提供报警提示, 提高驾驶安全性。

Wheel formula 车轮模式

- 14 × 8 × 14.

Outrigger 支腿

- H-type two-stage telescopic outriggers. The telescopic hydraulic system of outrigger adopts electric proportional control technology and is equipped with wireless remote control with high control precision and easy operation, which has the function of automatic leveling.
- 活动支腿采用双H型两级伸缩支腿, 支腿伸缩液压系统采用电比例控制技术, 并配置有无线遥控, 并具有自动调平等功能, 控制精度高, 操作简便。

Crane Introduction

整机介绍

Carrier 下车

Brake 制动系统

- Dual circuit, air brake, disc brakes available.
- Service brake: air servo brakes on all wheels, dual circuits, all wheels equipped with disc brakes.
- Parking brake: actuated by pressure accumulators on axles 2 to 7.
- Assist brake: engine brake and exhaust brake, transmission hydraulic retarder brake.
- 双回路、气制动、配备盘式制动器。
- 行车制动器：所有车轮均采用空气伺服制动器，双回路制动系统，新型盘式制动器。
- 驻车制动器：由蓄压器驱动作用在第二至第七桥上。
- 辅助制动器：发动机上带有发动机制动，变速箱配备液力缓速制动。。

Electrical system 电气系统

- 24 V DC power supply. Chassis power supply can be cut off; equipped with auto lighting system; actions of the vehicle such as throttle and outrigger control are realized by electrical control with easy and fast operation; the electrical system has strong detection, logic, operation and other capabilities, and has the functions of fault diagnosis, centralized display and self-protection.
- The chassis adopts CAN bus system, which is provided with: fast, stable and accurate data transmission; multi-functional centralized display system; high protection grade of IP65; low power consumption with a maximum of 5W; with four function keys provided in the user interface; LCD is used for display adjustable for contrast.
- 采用24V直流电源，可实现下车电源切断；配备汽车照明系统；车辆的动作，如油门、支腿操纵等都经电气控制实现，使动作轻便、快捷；电气系统有很强的检测、逻辑、运算等能力，具故障自诊断、集中显示及自我保护功能。
- 底盘采用 CAN 总线系统，具有数据快速、稳定、准确等优点；多功能的集中显示系统；防护等级高，IP65；功率消耗小，最大仅有5w；在用户界面提供四个功能键；显示采用LCD 液晶，对比度可调整。

Crane Introduction

整机介绍

Operator's cab 操纵室

- Sany new type operator's cab, which can be tilted upward by 20°. It adopts corrosion-resistant steel plate, it is provided with full coverage softened interior, panoramic sunroof, tilt positioning of operator seat back and other human centered design make the operation comfortable and easy. Configure main and auxiliary display screens to seamlessly integrate the main console with the operating display system, providing a clear and comprehensive view of all operating condition data during the lifting operation. Touch screen with adjustable viewing angle, multi-screen and multi-angle monitoring to ensure operation safety and realize one-touch operation, the main boom, luffing jib and superlift hoist are equipped with monitors for centralized monitoring in key areas. Perfect combination of main console and operation display system enables quick and easy human-computer interaction, heating and cooling A/C is provided.
- 三一新款操纵室, 0°~20°可变角度, 采用耐腐蚀钢板, 配置全覆盖软化内饰、全景式天窗、可倾式座椅等人性化设计, 操作更舒适、轻松; 配置主、辅显示屏, 实现主控台与操作显示系统有机结合, 使吊装作业的全部工况数据一目了然; 触摸式显示屏, 视角可调节、多画面、多角度监控保证作业安全, 满足一键式操作; 主臂及超起卷扬配备监视器, 重点区域集中监视; 主控台与操作显示系统有机结合, 人机交互方便快捷; 配备冷暖空调。

Superstructure engine 上车发动机

- Model: WEICHAH WP7G300E473, electronically controlled, in-line six-cylinder, watercooled, supercharged intercooled and diesel engine.
- Power: 221kW/2200rpm.
- Torque: 1200N·m/(1400~1600)rpm.
- Emission standard: complying with China IV.
- Fuel reservoir capacity: 330L.
- 型式: 潍柴WP7G300E473, 电控、直列六缸、水冷却、增压中冷、柴油发动机。
- 功率: 221kW/2200r/min。
- 最大扭矩: 1200N·m/(1400~1600)rpm。
- 排放标准: 排放符合国IV标准。
- 燃料箱有效容积: 330L。

Slewing 回转系统

- It is composed of fixed displacement motor and slewing reducer with mature technology and widely used on wheel cranes, at the same time, it adopts external meshing with slewing bearing to realize 360° full-slewing and stepless speed regulation; the slewing hydraulic system adopts a closed system, which can not only avoid the throttling loss of the open system, but also make the system have high efficiency; electric proportional brake pedal is used to realize emergency braking.
- 由技术成熟、并在汽车起重机上广泛使用的定量马达和回转减速机组成, 同时与回转支承采用外啮合形式, 以实现360°全回转, 回转速度可从0~1.2rpm, 无级调速; 回转液压系统采用闭式系统, 即能够避免开式系统的节流损失, 又使系统具有较高的效率; 电比例制动踏板, 可实现紧急制动。

Slewing platform 转台结构

- Designed and manufactured by SANY, the turntable made by fine-grained highstrength steel has a better structure.
- 三一自主设计, 结构更优化, 由细晶粒高强度钢制成。

Boom system 吊臂系统

- Main boom: It is composed of 1 base boom and 7 telescopic sections. It is made of fine-grained high-strength steel plates by bending and welding, with U shape profile, it has good buckling resistance; the single cylinder automatic pinning system is adopted, and a double-acting cylinder can control the extension and retraction of all booms to achieve a combination of multiple boom lengths; the basic boom length is 17.2m and the full extension boom length is 90.1m.
- Jib: There are fixed jib: the fixed jib shares the adapter, jib head, 6m and 12m large (small) section standard sections, which can realize the jib length combination of 8m~48m. The offset can be changed according to the actual needs of working conditions to improve the automation level, reduce the labor intensity and improve the work efficiency.
- Superlift device: It's arranged on the left and right sides of the head of the base boom, and independent from each other, and it can realize assembly and disassembly without auxiliary crane. The superlift device can greatly improve the stress state of the boom, avoid side bending and reduce the downward deflection deformation of the boom, so that the deflection in the long boom state can be reduced by 20%-30% and the lifting capacity can be improved by more than 200%.
- 主臂: 由1节基本臂和7节伸缩臂组成, 采用细晶粒高强度钢板折弯、焊接制成, 采用U形截面, 抗屈曲性能好; 采用单缸自动插销式系统, 一个双作用油缸可以控制所有吊臂的伸缩, 达到多种臂长组合; 基本臂长17.2m, 全伸臂长90.1m。
- 副臂: 有固定副臂: 固定副臂有转接头、副臂臂头、6m及12m大(小)截面标准节, 可以实现8m~48m的臂长组合, 可以根据工况的实际需要而变化角度, 提高了自动化水平, 减轻了劳动强度, 提高了工作效率。
- 超起: 布置于基本臂头部左右两侧, 左右独立, 无需辅助吊装可实现自拆装; 超起装置使得起重臂的受力状态得到很大改善, 避免旁弯, 减小起重臂的下挠变形, 起重臂在长臂状态下挠度可减小20%-30%, 起重性能提升200%以上。

Hoist 起升机构

- Main hoist: Planetary gear reducer driven by hydraulic motor and special rope groove winch drum, with a built-in brake.
- Wire rope lock: The end of the wire rope is cast and directly installed in the lock sleeve, which improves the reeving speed.
- Specification of wire rope: $\phi 24$ -2160, non-rotating wire rope.
- Max. single rope speed (the seventh layer): approx. 130m/min.
- 液压马达驱动的行星齿轮减速机和专用绳槽卷扬鼓, 内置制动器。
- 钢丝绳锁具: 采用高品质钢丝绳锁, 钢丝绳端浇铸, 直接安装于锁套内, 提高了起重倍率的更换速度, 方便快捷。
- 钢丝绳规格: $\phi 24$ -2160, 抗旋转钢丝绳。
- 最大单绳速(第七层): 约130m/min。

Luffing system 变幅系统

- Double cylinders are adopted, the hydraulic system adopts dual-pump converging open hydraulic circuit, and the combination of electric proportional control, active luffing and passive luffing down can realize fast luffing at large elevation and stable slow luffing at small elevation.
- Luffing angle: 0°~84°.
- 双油缸前顶式变幅, 变幅角度0°~84°, 液压系统采用双泵合流开式液压回路, 采用电比例控制、动力落幅和自重落幅相结合, 可实现大角度快速落幅, 小角度稳定慢速落幅。

Crane Introduction

整机介绍

Superstructure 上车

Hydraulics 液压系统

- The open and closed independent hydraulic system of the superstructure has the characteristics of high load sensitivity, heavy load low speed, low load high speed and high action efficiency. The luffing and telescopic system adopts an open system composed of an electro proportional pump and a self-made main valve, which has four pressure levels for selection, and different pressure levels are used for different actions, combined with the displacement of the electric proportional pump, so as to realize energysaving and safe luffing and telescopic actions; the hoist system adopts a closed system to avoid the throttling loss of open system, so that the system has high efficiency and wide speed regulation range; the slewing system is a closed system, which can avoid the throttling loss of open system, so that the system has high efficiency and good inching-movement performance; in addition to the functions of superstructure slewing, boom luffing, extension and retraction, and main and auxiliary hoist lifting, it can also realize the functions of counterweight lifting, operator's cab rotation, and turntable locking.
- The pump, piston motor and balanced valve adopt highquality components with high reliability; the electric proportional variable displacement piston pump can adjust the displacement of the oil pump in real time, realizing high-precision flow control and minimize energy waste; the dual-pump converging/shunting main valve independently developed by SANY has high converging efficiency of single action dual-pump and high shunting controllability of combined action dual-pump.
- The hydraulic system with passive luffing down compensation is adopted, which has good luffing down inching-movement and stability.
- The main boom adopts a single cylinder pin telescopic system.
- 开闭式相结合的上车液压系统, 具有负载感知特性、重载低速、轻载高速、动作效率高的特点。其中变幅伸缩系统采用电控比例泵与自制主阀组成的开式系统, 具有压力一键标定以及智能修正功能, 不同动作采用不同的压力等级, 配合电比例泵排量, 从而实现节能、安全的变幅和伸缩动作; 起升卷扬系统采用闭式系统, 不仅起落钩动作响应敏捷, 还作业效率高, 调速范围宽; 回转采用闭式系统, 系统启停平稳无延时, 动作柔顺且微控性好; 除可实现上车回转、吊臂变幅、伸缩、主卷扬起落功能外, 还可实现平衡重升降、转台锁止等的功能。
- 液压泵、柱塞马达及平衡阀等关键元件均采用国际一线品牌, 品质好, 可靠性高; 开、闭式电比例泵, 实时调节排量, 实现高精度流量控制, 最大化减少能量浪费; 自主研发的双泵合/分流主阀, 实现系统压力与流量无极调节以及互不干扰的双回路控制, 单动作双泵合流效率高, 组合动作双泵分流操控及平顺性好; 变幅采用自重与加压落幅补偿液压系统, 落幅微动性、平稳性好。主臂伸缩采用单缸插销式快速伸缩系统。

Control system 控制系统

- Powered by 24 V DC, it adopts IFM controller, cable wiring, CAN-BUS control network, and combines with conventional electrical to realize the logic control and electrical proportional control functions of the system.
- It has the functions of system real-time monitoring and automatic fault diagnosis.
- Lifting, slewing and luffing are controlled by two auto resettable multidirectional electric proportional joystick; boom extension and retraction are controlled by pedal; counterweight lifting, operator's cab tilting and turntable locking are all controlled by keys on the control panel.
- The display is connected with the controller by CAN bus, and its main functions include digital adjustment and display of electric proportional control parameters, fault code display of electric proportional system and real-time detection data display of hydraulic system.
- 由24V直流电源供电, 采用德国进口IFM控制器、电缆布线, CAN-BUS总线控制网络, 与常规电气相结合, 完成系统的逻辑控制与电比例控制功能。
- 具有系统实时监测和故障自动诊断功能。
- 起升、回转、变幅由两个可自动复位多方向电比例手柄控制; 伸缩由脚踏式伸缩踏板操纵; 平衡重升降、操纵室变位、转台锁止均在操纵面板按键控制。
- 显示器由CAN总线与控制器联接, 主要功能: 电比例控制参数的数字化调整和显示, 电比例系统的故障代码显示, 液压系统实时检测数据的显示。

Counterweight 配重

- Combined variable counterweight. 13 combinations from 23t to 143t can meet the needs of different working conditions, maximize the performance of structural parts, achieve remote removal and installation, and a good inching-movement.
- 组合式可变平衡重23t-143, 共13种组合方式, 可满足不同工况的需求, 最大限度发挥结构件性能, 可遥控拆卸及安装, 微动性好。

Safety equipment 安全装置

- A method of analytical mechanics is adopted and a load moment indicator calculation system based on the lifting mechanics model is established. Through online empty-load calibration, the lifting accuracy can reach $\pm 3\%$.
- The hydraulic system is equipped with hydraulic balance valve, relief valve, two-way hydraulic lock, etc. to realize the stability and reliability of the hydraulic system.
- The boom and luffing jib hoists are equipped with 3rd wrap indicators to prevent over-hoist-down of the wire rope.
- The boom head and jib head are equipped with A2B switch to prevent the wire rope from over winding.
- The boom head is equipped with an anemometer to detect whether the wind speed exceeds the allowable range.
- Superlift device retracting and releasing rope tension protection, luffing (fixed) jib installation and lifting protection.
- 采用分析力学方法, 建立了基于吊重力学模型的力矩限制器计算系统, 通过在线空载标定, 吊重精度达到 $\pm 3\%$ 。
- 液压系统配置液压平衡阀、溢流阀、双向液压锁等元件, 实现液压系统稳定可靠。
- 卷扬配置三圈保护器, 防止钢丝绳过放。
- 臂端配置高度限位器, 防止钢丝绳过卷。
- 臂端装有风速仪, 检测高空风速是否超过可作业允许范围。
- 超起收放绳拉力保护程序, 塔(副)臂安装、吊载保护程序等。

Optional equipment at extra fees 选配

- Superstructure/chassis Mercedes-Benz engine.
- 84m luffing jib/Air intake shutoff valve/Spark arrester/Boom tip camera/ Lightning protection device/Customized painting/ Other equipment available upon request.
- 上车/下车奔驰发动机。
- 84m塔臂/进气切断阀/火星灭火器/臂尖摄像头/防雷装置/特殊涂装/其他选配视需求定。

Counterweight Combinations

配重组合

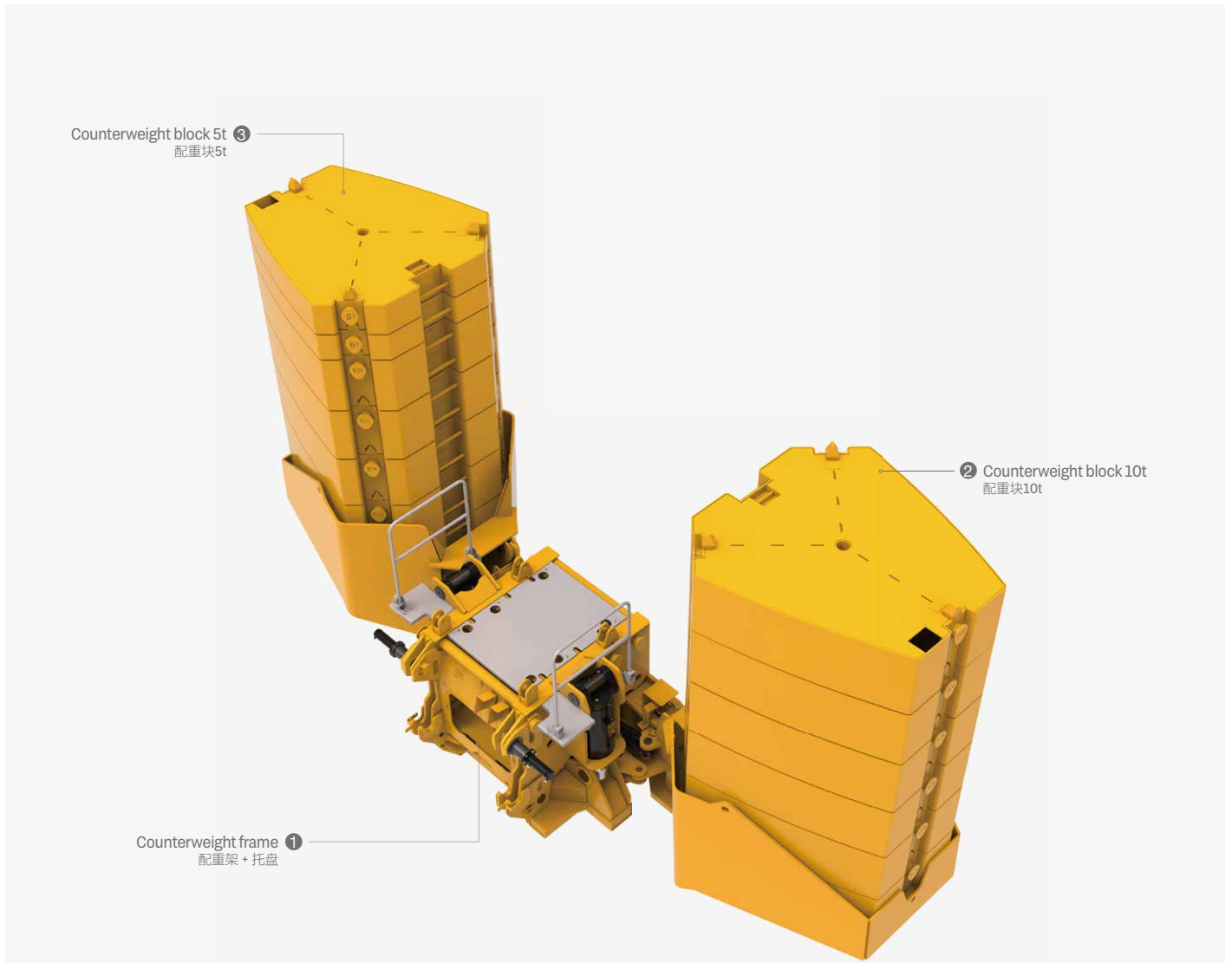

Total weight 总重量	Counterweight Combinations 配重组合
0	0
23	①
33	① + ③ × 2
43	① + ② × 2
53	① + ② × 2 + ③ × 2
63	① + ② × 4
73	① + ② × 4 + ③ × 2
83	① + ② × 6
93	① + ② × 6 + ③ × 2
103	① + ② × 8
113	① + ② × 8 + ③ × 2
123	① + ② × 10
133	① + ② × 10 + ③ × 2
143	① + ② × 11 + ③ × 2

Jib Assembly

副臂组合

Fixed jib assembly (standard) 固定副臂(标配)

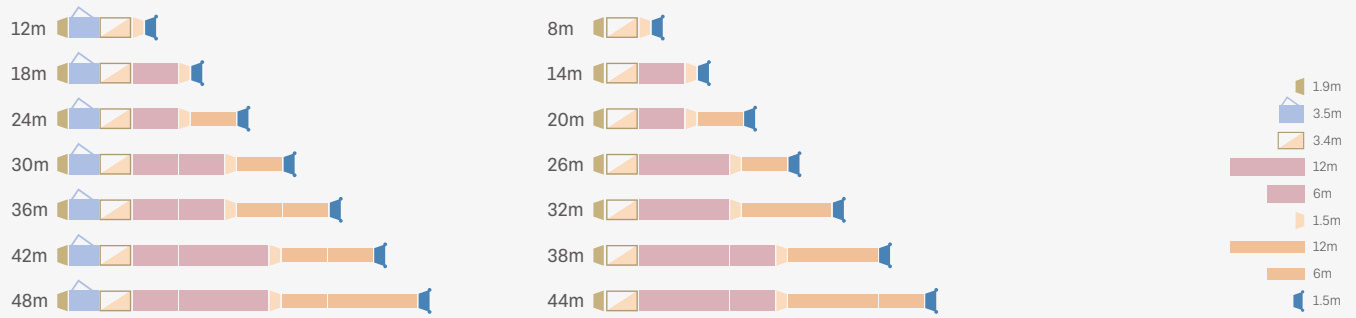

Luffing jib assembly (optional) 变幅副臂(选配)

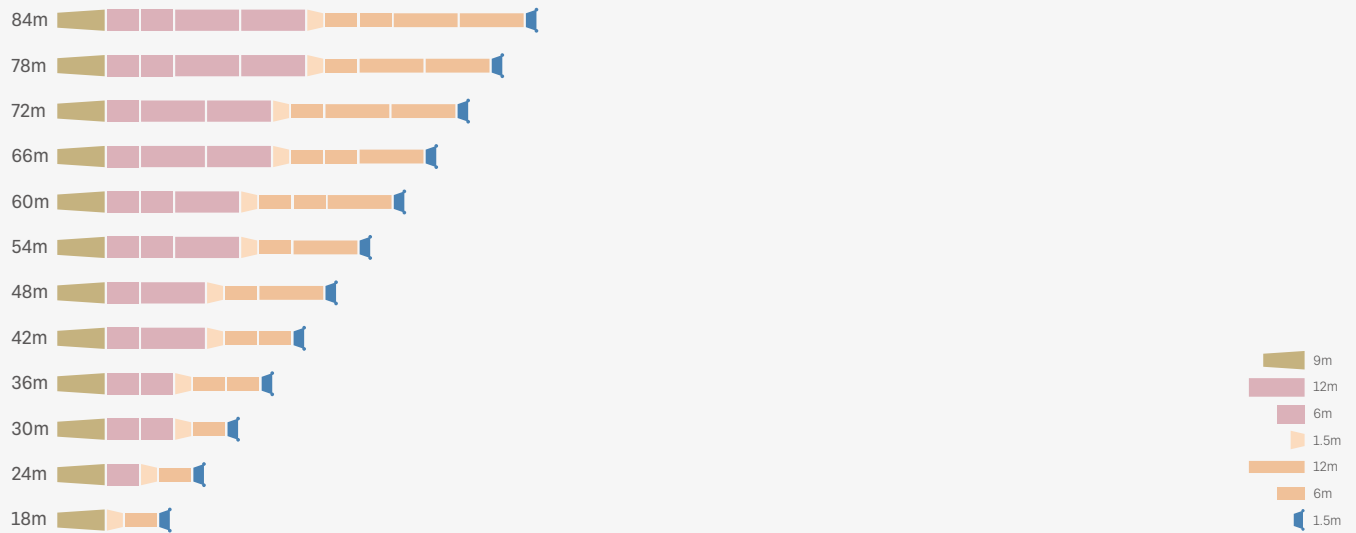

On-Site Heavy-Duty Driving Solutions

重载转场方案

- ① Without boom section 3-7, outriggers, hook, superlift, counterweight, counterweight frame, jib and outrigger pads
拆 3-7 节臂、前支腿、后支腿，不带吊钩、超起、配重及配重架、副臂、支腿垫板

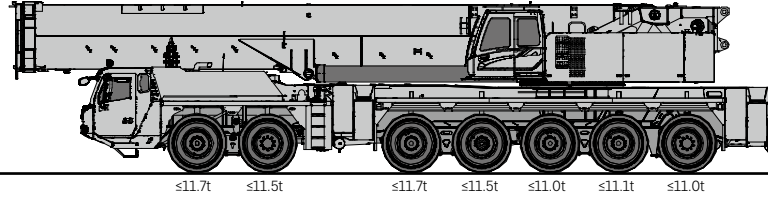

70km/h ≤79.5t

- ② Without boom section 3-7, rear outriggers, hook, superlift, counterweight, counterweight frame, jib and outrigger pads
拆 3-7 节臂、后支腿，不带吊钩、超起、配重及配重架、副臂、支腿垫板

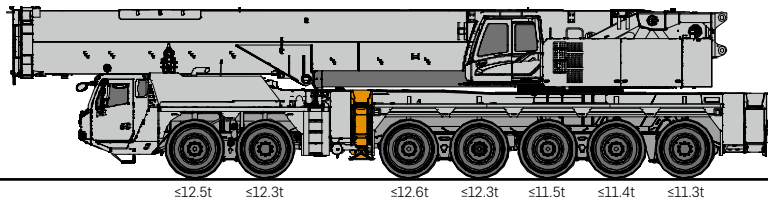

70km/h ≤83.9t

- ③ Without boom section 3-7, hook, superlift, counterweight, counterweight frame, jib and outrigger pads
拆 3-7 节臂、不带吊钩、超起、配重及配重架、副臂、支腿垫板

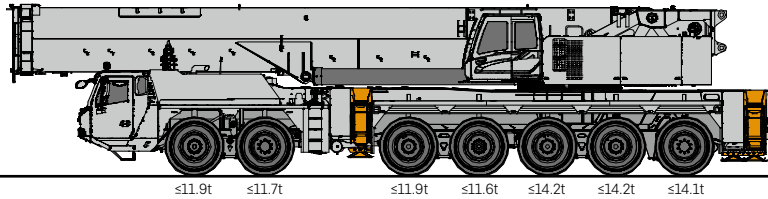

70km/h ≤89.6t

- ④ Without hook, superlift, counterweight, counterweight frame, jib and outrigger pads
不带吊钩、超起、配重及配重架、副臂、支腿垫板

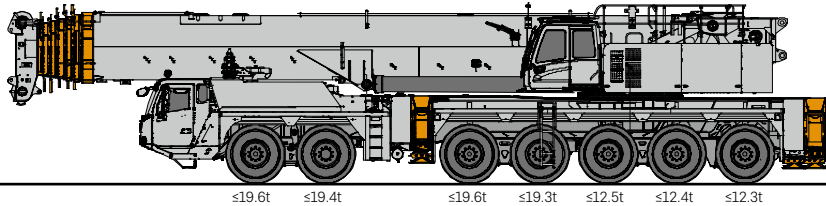

70km/h ≤115.1t

- ⑤ Without hook, superlift, counterweight, counterweight frame, jib
不带吊钩、超起、配重及配重架、副臂

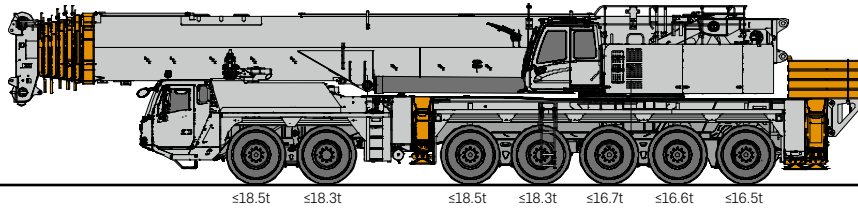

40km/h ≤123.4t

- ⑥ Without hook, counterweight, counterweight frame, jib
不带吊钩、配重及配重架、副臂

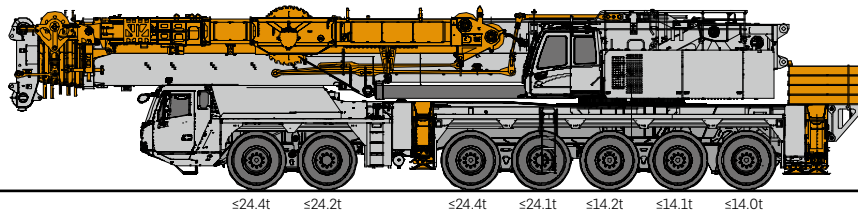

40km/h ≤139.4t

Operating Range - Telescopic Boom (T)

起升高度曲线 - 主臂

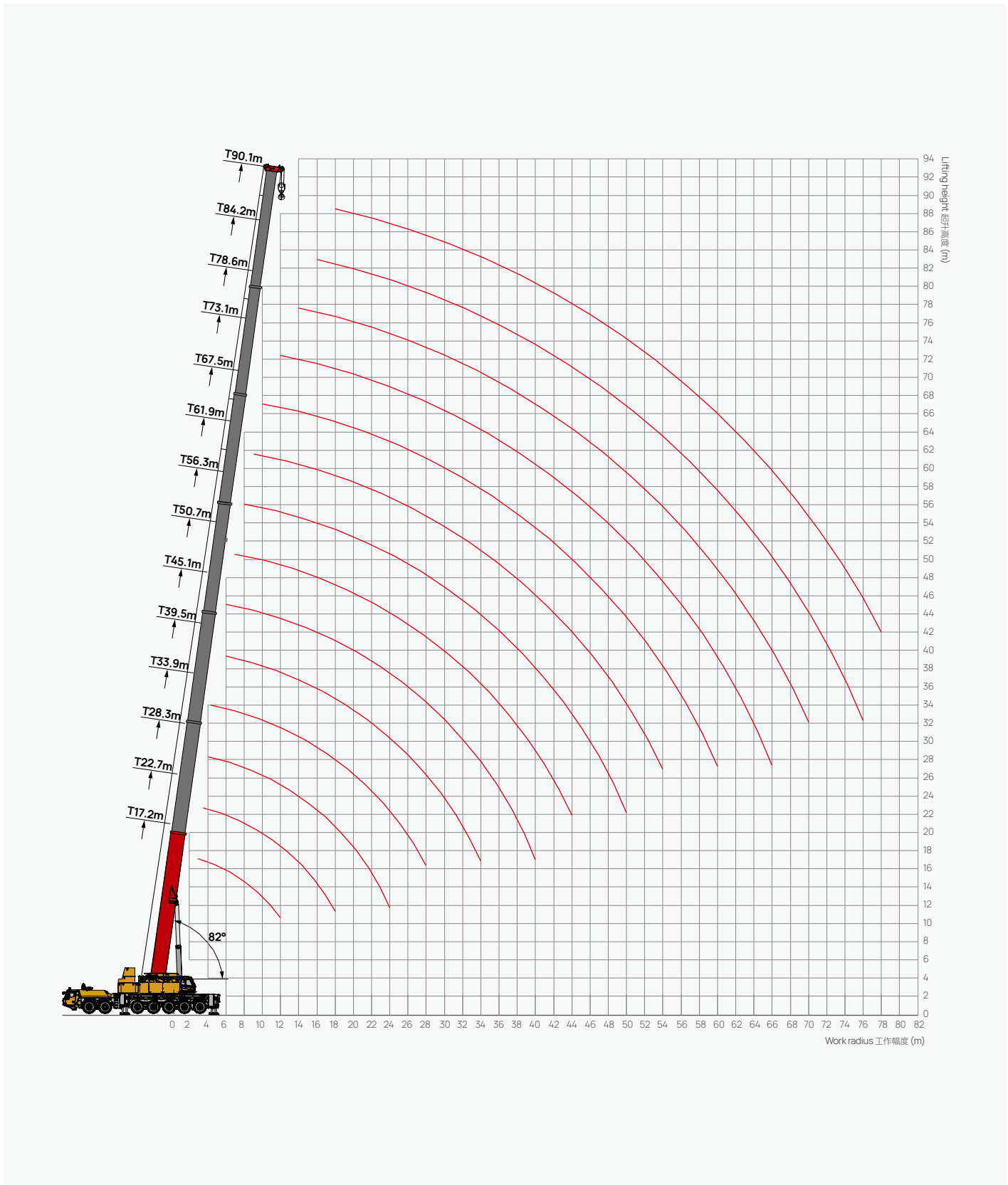



Load Chart - Telescopic Boom (T)

性能表 - 主臂

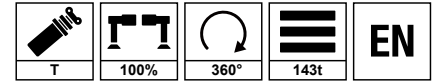
Unit: t



	17.2	22.7	28.3	33.9	39.5	45.1	50.7	56.3	61.9	67.5	73.1	78.6	84.2	90.1	
3	600**														3
3.5	230*	230*													3.5
4	230*	230*	205*												4
4.5	230*	230*	200	188											4.5
5	228*	226*	195	185											5
6	215*	210*	192	181	166	135									6
7	195	192	185	175	162	132	115								7
8	179	175	170	165	156	130	112	73							8
9	164	164	160	155	146	125	109	71.6	55						9
10	150	150	150	145	137	121	105	69.8	54.1	48					10
12	127	130	130	124.7	123.1	111.6	100	66.6	52.6	46	42.3				12
14		110	108	108	105	102	93.6	63.1	51	44.6	38.5	35			14
16		93	92	93	91	90	85.3	59	49.7	43.2	36.8	34	28		16
18		75	81	81	81	80	76	56	47.4	41	35.5	32.8	27.1	22	18
20			71	71	73	70	68	52.5	45.4	39.2	34.1	30.4	26	21.8	20
22			64	63	64	64	60.8	49.2	41.9	37.6	32.8	29.1	25.2	21	22
24			46	57	57	59	54.3	46.1	41	35.9	31.6	28	24	20.8	24
26				50	51	53	48.9	43.5	38.1	33.6	30.5	26.7	23.1	20.4	26
28				42	46	48	44.3	40.6	34.5	31	29	25.3	22.3	20	28
30					41	43	40.3	38	32.5	29	27.2	24	21.4	19.6	30
32					37	39	36.8	36.1	28.8	27	25.5	23	20.6	18.8	32
34					31.5	36	34.7	34	25.7	26	23.2	21.9	19.7	18.2	34
36						32.4	32.8	32.2	24.3	24.6	21.6	20.8	18.8	17.4	36
38						30	30.5	29.7	23	22.5	20.5	19.5	17.9	16.5	38
40						22	28.2	27.5	21.1	21.1	19.6	18.4	16.9	15.7	40
42							26	25.5	19	20.1	18.4	17.5	16.2	14.6	42
44							22.2	23.7	18.1	18	17.5	16.5	15.2	13.8	44
46								22.1	16.8	16.5	15.8	15.5	14.3	13.1	46
48								20.4	15.4	15.2	14.8	14.5	13.6	12.2	48
50								14.5	14.4	14	13.5	13.5	13.1	11.6	50
52									13.8	13	12.9	12.8	12.3	10.9	52
54									12.7	12	12.2	12	11.4	10.2	54
56										11	11.6	11.5	10.8	9.3	56
58										10	11	10.9	10.3	8.6	58
60										8.8	10.5	10.2	9.5	8	60
62										8	9.8	9.5	9	7.5	62
64											8	8.9	8	6.8	64
66											6.8	8.6	7.6	6.2	66
68												8.2	6.5	5.8	68
70												6.5	6	5.3	70
72													5.2	4.6	72
74													4.5	4.1	74
76													3.2	3.5	76
78														3.1	78

Remark:
 ** Requires additional equipment, aft-facing hoist operation.
 * Requires additional equipment.
 备注:
 ** 代表需使用附加装置, 正后方作业。
 * 代表需使用附加装置。

Operating Range - Telescopic Boom + Superlift Device (TS)

起升高度曲线 - 主臂 + 超起

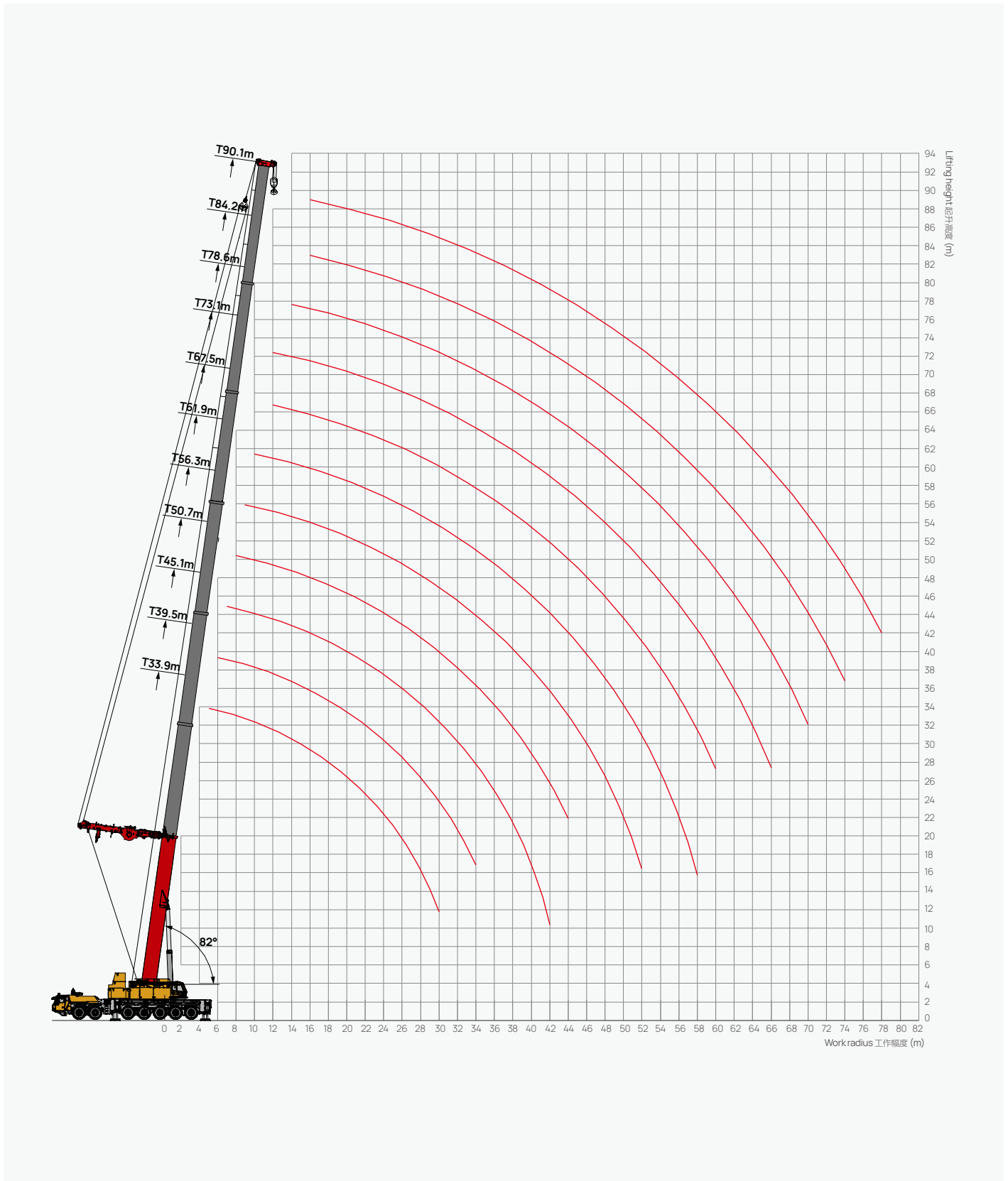



Load Chart - Telescopic Boom + Superlift Device (TS)

性能表 - 主臂 + 超起

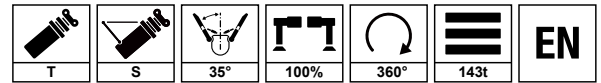
Unit: t



	33.9	39.5	45.1	50.7	56.3	61.9	67.5	73	78.6	84.2	90.1	
5	190											5
6	190	181.5										6
7	185	179.3	156.2									7
8	168.7	170.1	154	148.5								8
9	152.9	154.5	149.6	143	132							9
10	139.7	143	138.6	137.5	127.6	115.5						10
12	118.7	122.7	120.8	119	116.7	110	104.5	93.5				12
14	102.6	107	105.2	103.5	101.2	100.2	99	88	77			14
16	89.7	94.6	92.9	91.3	91.3	90.8	88.5	85.8	74.8	71.5	53	16
18	76.6	83.7	82.9	82.5	81.8	81.1	79.4	79	72.6	63.8	50.1	18
20	66.1	73.6	75.3	75.1	73.7	74.8	73.1	71.7	69.3	61.6	47.3	20
22	59.4	66.6	67	66.7	66.3	68.2	67.3	65.6	63.5	58.3	45.1	22
24	56.1	59.9	59.9	59.5	61.5	61.4	61	60.5	59.4	55	41	24
26	49.3	53.8	54.5	53.9	55.6	55.4	55.1	54.6	54.1	51.8	38	26
28	44.8	48.6	49.7	50.2	50.4	50.3	50	49.6	49	48.2	35	28
30	35.3	44.1	45.2	45.7	45.9	45.8	45.6	45.1	44.5	43.8	33	30
32		40.2	41.3	41.8	42	41.9	41.7	41.2	40.7	39.8	31	32
34		30.8	37.8	38.4	38.6	38.5	38.2	37.8	37.2	36.5	28.6	34
36			34.8	35.3	35.5	35.5	35.2	34.8	34.2	33.5	26.4	36
38			31.1	32.5	32.8	32.8	32.5	32.1	31.4	30.7	24.2	38
40			26.5	30.1	30.4	30.3	30	29.6	29	28.3	22.6	40
42			18.7	27.9	28.1	28	27.8	27.4	26.8	26.1	21.3	42
44				24.2	26.1	26	25.8	25.3	24.8	24.1	19.6	44
46					24.2	24.2	24	23.6	23	22.3	18.1	46
48					20.9	22.5	22.3	21.9	21.3	20.6	16.8	48
50					16.5	20.9	20.8	20.3	19.8	19.1	15.3	50
52					13.5	19.5	19.3	18.9	18.4	17.7	14.3	52
54						16.5	18	17.6	17	16.3	13.1	54
56						13.5	16.8	16.4	15.7	15.1	12.2	56
58						10	15.4	15.2	14.6	14	11.4	58
60							12.1	14.1	13.6	12.6	10.5	60
62								13.1	12.5	11.7	9.7	62
64								12	11.6	10.9	8.8	64
66								9.9	10.8	10.1	8	66
68									9.9	8.9	7.2	68
70									8.6	7.9	6.5	70
72										6.8	6	72
74										5.9	5.4	74
76											4.8	76
78											4.2	78
80												80

Operating Range - Telescopic Boom + Fixed Jib (TJ)

起升高度曲线 - 主臂 + 固定副臂

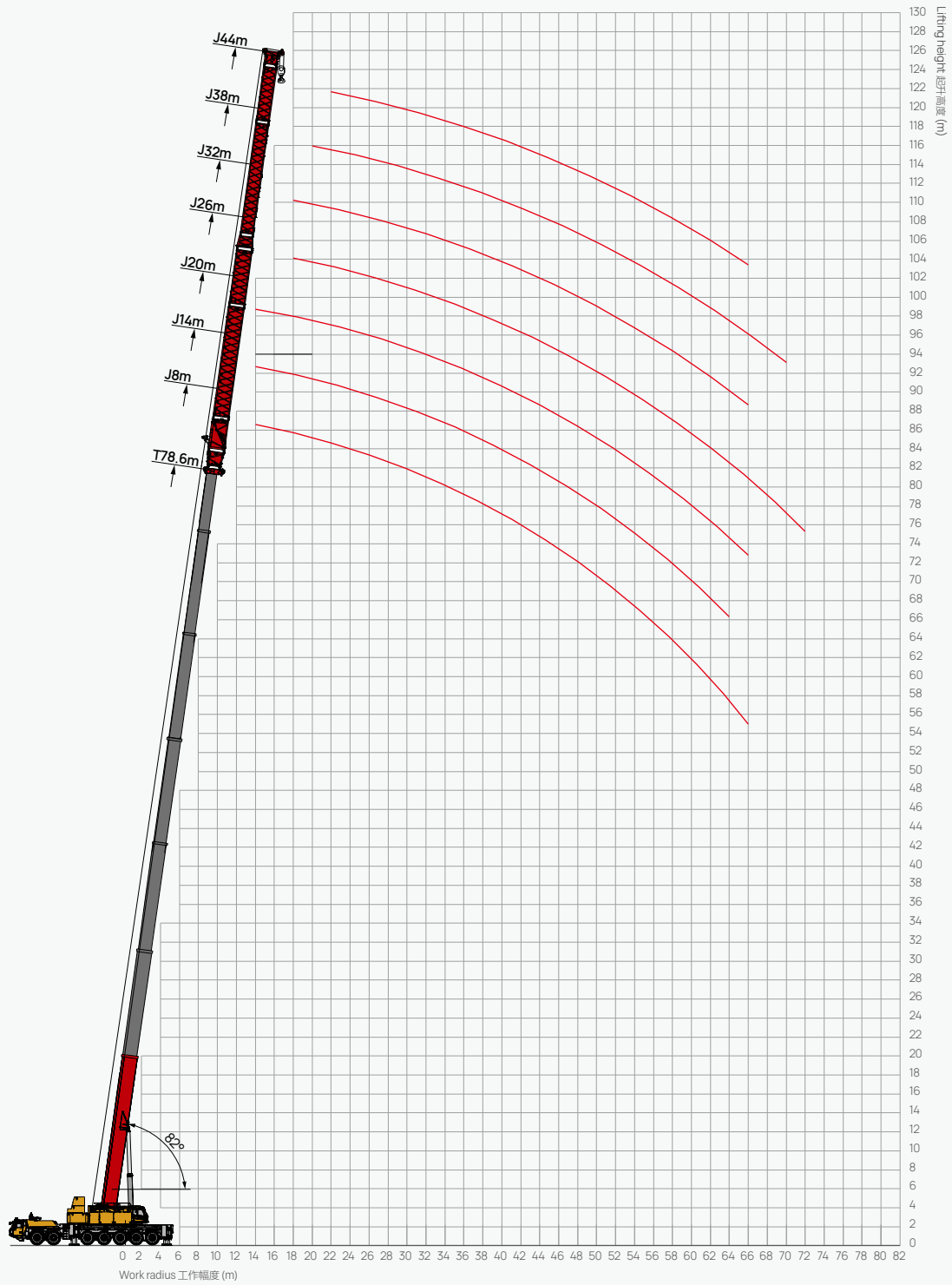

Load Chart - Telescopic Boom + Fixed Jib (TJ)

性能表 - 主臂 + 固定副臂

Unit: t

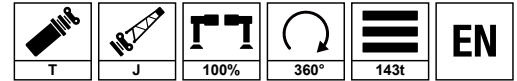

m	61.9m+44m			67.5m+44m			73m+44m			78.6m+44m		m
	0°	20°	40°	0°	20°	40°	0°	20°	40°	0°	20°	
10												10
12												12
14												14
16												16
18	10.2											18
20	9.8			9.5			8.2					20
22	9.2			8.9			7.6			6.7		22
24	8.6			8.2			7.0			6.2		24
26	8.0			7.5			6.6			5.7		26
28	7.3			6.9			6.2			5.4		28
30	6.8	5.3		6.3			5.7			5.0		30
32	6.4	4.9		5.8	4.6		5.3	4.0		4.6		32
34	6.0	4.5		5.4	4.2		4.9	3.6		4.3	3.1	34
36	5.7	4.3		5.1	4.1		4.7	3.6		4.0	2.8	36
38	5.5	4.0		5.0	3.9		4.6	3.4		3.8	2.8	38
40	5.3	3.8		4.9	3.6		4.4	3.2		3.7	2.6	40
42	5.0	3.6		4.6	3.4		4.3	3.0		3.6	2.4	42
44	4.7	3.4	2.4	4.4	3.2		4.2	2.8		3.5	2.3	44
46	4.6	3.2	2.3	4.3	3.1	2.3	4.1	2.8	1.9	3.4	2.2	46
48	4.4	3.0	2.3	4.1	2.9	2.3	3.7	2.6	1.9	3.3	2.1	48
50	4.2	2.7	2.1	3.9	2.7	2.1	3.6	2.4	1.8	3.0	2.0	50
52	4.0	2.6	2.1	3.7	2.5	2.1	3.4	2.2	1.8	2.9	1.8	52
54	3.7	2.4	2.1	3.5	2.4	2.0	3.3	2.2	1.7	2.8	1.7	54
56	3.6	2.4	2.0	3.3	2.3	2.0	3.1	2.1	1.7	2.6	1.6	56
58	3.5	2.3	2.0	3.1	2.2	1.9	2.9	2.0	1.6	2.5	1.6	58
60	3.2	2.2	1.9	2.9	2.2	1.9	2.7	2.0	1.6	2.3	1.5	60
62	2.9	2.2	1.9	2.7	2.1	1.9	2.5	1.9	1.6	2.1	1.5	62
64	2.7	2.1	1.9	2.5	2.1	1.9	2.3	1.9	1.6	2.0		64
66	2.5	2.1	1.9	2.3	2.0	1.8	2.1	1.8	1.5	1.8		66
68	2.3	2.0	1.8	2.1	1.7	1.8	1.8	1.6	1.5			68
70	2.1	1.9	1.8	1.8	1.6	1.8		1.5				70
72	1.8	1.7	1.8	1.6	1.4	1.8						72
74	1.6	1.6	1.8			1.6						74
76												76
78												78
80												80
⚖	2	1	1	1	1	1	1	1	1	1	1	⚖

Operating Range - Telescopic Boom + Fixed Jib + Superlift Device (TSJ)

起升高度曲线 - 主臂 + 固定副臂 + 超起

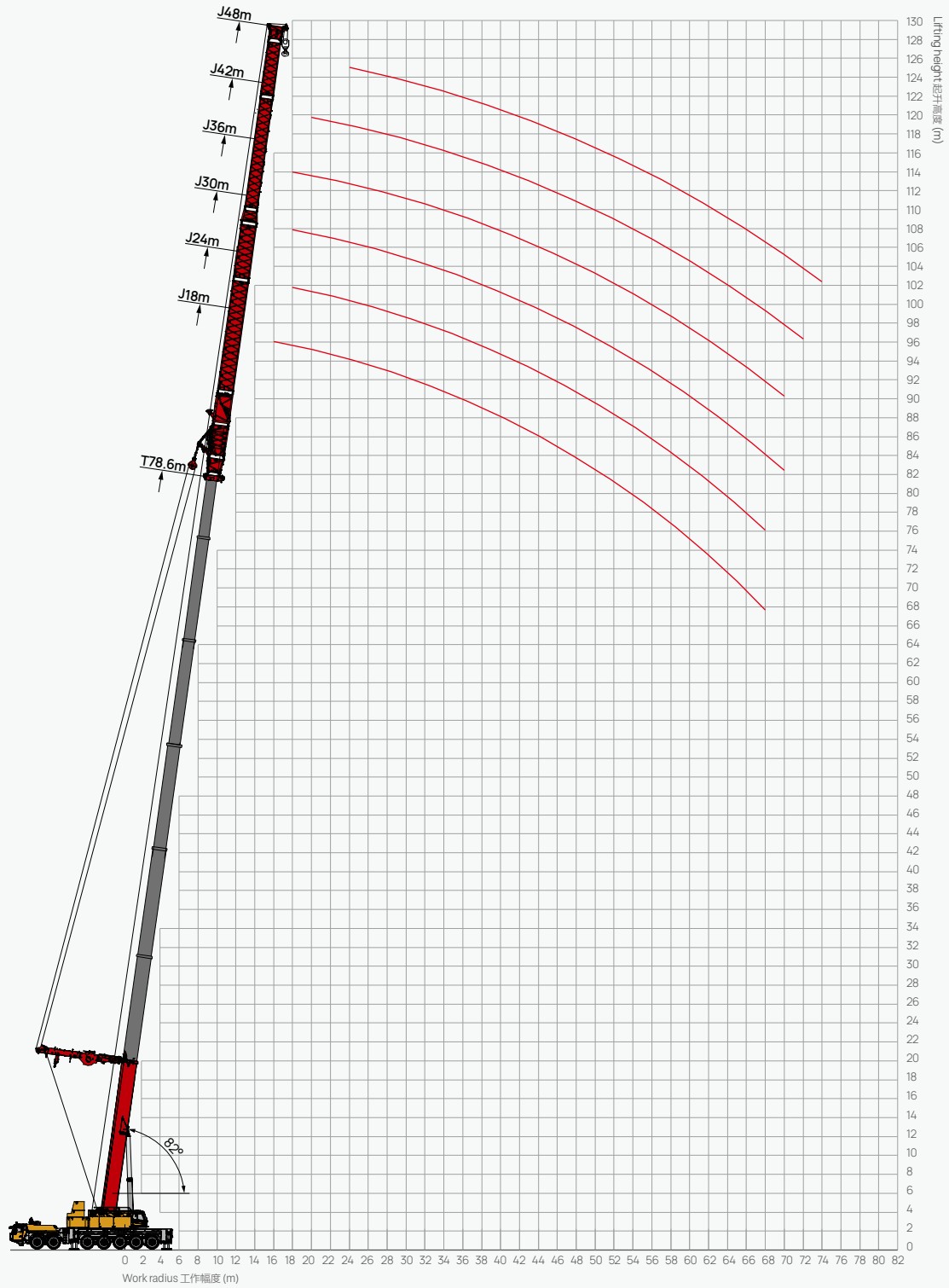

Load Chart - Telescopic Boom + Fixed Jib + Superlift Device (TSJ)

性能表 - 主臂 + 固定副臂 + 超起

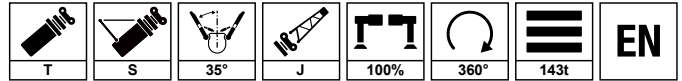

Unit: t

Lift Height m	67.5m + 48m			73m + 48m			78.6m + 48m			Lift Height m
	0°	20°	40°	0°	20°	40°	0°	20°	40°	
18										18
20	15.4									20
22	14.7			13.0						22
24	14.2			12.4			11.4			24
26	13.5			12.0			10.8			26
28	12.8			11.4			10.5			28
30	12.2			10.8			9.9			30
32	11.8			10.3			9.4			32
34	11.2	6.7		9.9			8.9			34
36	10.7	6.5		9.4	5.9		8.6	5.1		36
38	10.2	6.3		9.0	5.7		8.2	4.9		38
40	9.7	6.1		8.6	5.5		7.8	4.8		40
42	9.2	5.9		8.1	5.4		7.4	4.6		42
44	8.6	5.7	3.4	7.7	5.2		7.0	4.4		44
46	8.0	5.5	3.3	7.2	5.0	3.0	6.6	4.3	2.6	46
48	7.4	5.3	3.2	6.7	4.8	2.9	6.2	4.1	2.5	48
50	6.8	5.1	3.1	6.2	4.6	2.9	5.7	4.0	2.4	50
52	6.2	4.9	3.0	5.6	4.4	2.8	5.2	3.8	2.3	52
54	5.6	4.6	2.9	5.1	4.3	2.7	4.8	3.6	2.3	54
56	5.0	4.3	2.9	4.6	4.0	2.6	4.3	3.4	2.2	56
58	4.6	4.0	2.8	4.1	3.7	2.6	3.9	3.1	2.2	58
60	4.2	3.7	2.7	3.8	3.4	2.5	3.4	2.9	2.1	60
62	3.8	3.4	2.7	3.4	3.1	2.4	3.1	2.6	2.0	62
64	3.4	3.0	2.6	3.1	2.8	2.4	2.8	2.4	2.0	64
66	3.0	2.7	2.5	2.7	2.5	2.3	2.5	2.0	1.9	66
68	2.6	2.5	2.4	2.4	2.2	2.2	2.2	1.8	1.8	68
70	2.2	2.2	2.2	2.0	2.0	2.1	1.9	1.6	1.7	70
72	1.7	2.0	2.0	1.7	1.7	1.9	1.6	1.4	1.5	72
74		1.7	1.7	1.3	1.5	1.7	1.3	1.1	1.3	74
76			1.4		1.2	1.4				76
78						1.2				78
80										80
Σ	2	1	1	2	1	1	1	1	1	Σ

Operating Range - Telescopic Boom + Luffing Jib + Superlift Device (TSL)

起升高度曲线 - 主臂 + 变幅副臂 + 超起

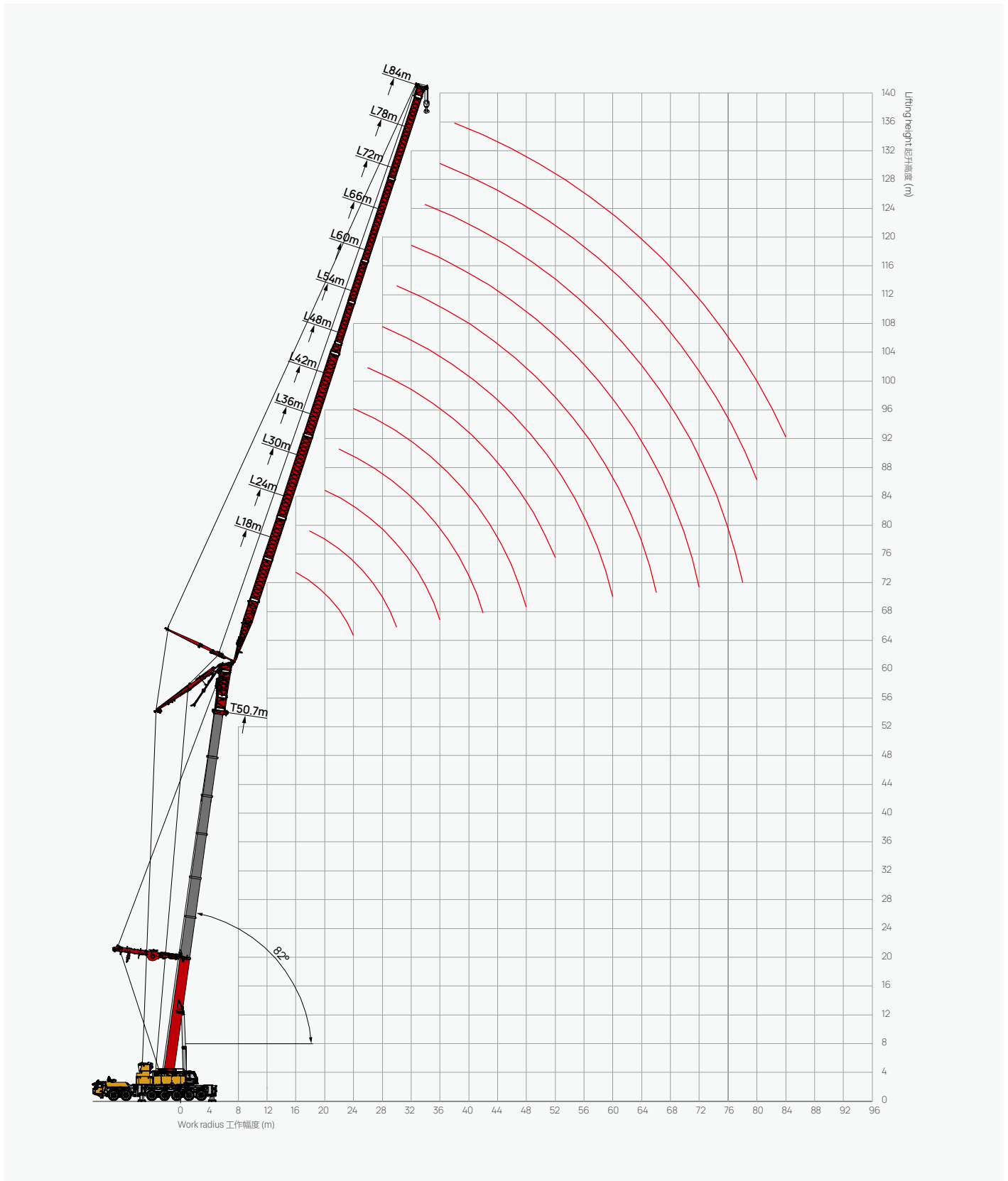

Load Chart - Telescopic Boom + Luffing Jib + Superlift Device (TSL)

性能表 - 主臂 + 变幅副臂 + 超起

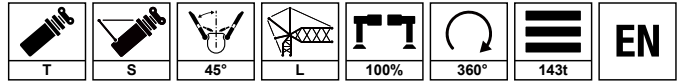

Unit: t

Jib m	39.5m												Jib m	
	18m	24m	30m	36m	42m	48m	54m	60m	66m	72m	78m	84m		
14	60.5													14
16	56.7	51.2												16
18	54.1	50.4	45.2											18
20	53.2	50.0	43.4	36.8										20
22	51.2	49.3	42.5	36.5	30.7									22
24		48.6	41.8	35.8	30.7	28.1								24
26		45.7	41.0	34.4	30.7	27.1	24.4							26
28		42.0	40.3	33.8	30.3	26.0	23.3	18.9						28
30			39.0	33.1	29.6	25.0	22.4	18.2	16.1					30
32			36.0	32.7	28.4	24.6	21.5	17.4	15.6	13.7				32
34			34.0	30.2	27.3	24.3	20.5	16.8	14.9	13.2	12.8			34
36				30.0	26.0	23.9	19.7	16.2	14.4	12.7	12.4	9.0		36
38				28.7	24.3	23.6	19.5	15.6	13.9	12.3	12.1	9.0		38
40				27.2	23.0	23.2	19.3	15.0	13.4	11.9	11.7	9.0		40
42					21.8	22.9	19.0	14.5	13.0	11.5	11.3	9.0		42
44					20.7	22.3	18.7	14.0	12.6	11.1	10.9	9.0		44
46					20.0	21.1	18.6	13.8	12.2	10.7	10.7	9.0		46
48						20.1	18.4	13.7	11.8	10.3	10.5	9.0		48
50						19.0	18.3	13.5	11.5	10.0	10.4	9.0		50
52							17.6	13.4	11.2	9.6	10.0	9.0		52
54							16.5	13.2	11.0	9.4	10.0	9.0		54
56							15.6	13.1	10.8	9.2	9.7	9.0		56
58							14.8	13.0	10.7	8.9	9.4	9.0		58
60								12.7	10.5	8.7	9.2	8.7		60
62								12.2	10.4	8.5	8.8	8.4		62
64									10.2	8.4	8.8	8.2		64
66									9.8	8.2	8.4	7.9		66
68									9.2	8.1	8.1	7.6		68
70									8.4	7.9	7.4	7.5		70
72										7.8	7.0	7.2		72
74										7.6	6.6	6.9		74
76										7.2	6.0	6.8		76
78											6.0	6.5		78
80												6.4		80
82												6.1		82
84												5.8		84
86														86
⚖	5	5	4	4	3	3	3	2	2	2	2	1	⚖	

Load Chart - Telescopic Boom + Luffing Jib + Superlift Device (TSL)

性能表 - 主臂 + 变幅副臂 + 超起

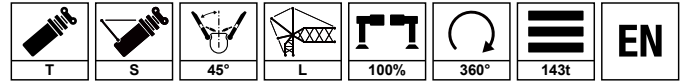

Unit: t

Jib m	45.1m												Jib m
	18m	24m	30m	36m	42m	48m	54m	60m	66m	72m	78m	84m	
14	58.0												14
16	54.4	46.4											16
18	51.9	45.7	39.7										18
20	51.0	45.3	38.1	35.2									20
22	49.1	44.6	37.4	35.2	28.3								22
24		44.0	36.7	35.2	28.3	26.0							24
26		41.4	36.1	34.0	28.3	25.1	23.9						26
28		38.1	35.4	32.9	27.1	24.0	23.2	18.1					28
30			34.3	31.7	26.6	24.2	22.1	17.5	15.6				30
32			31.6	31.0	25.9	23.5	21.2	16.8	15.0	12.6			32
34			29.8	29.5	25.5	22.8	20.4	16.2	14.5	12.3	11.1		34
36				28.2	24.8	22.2	19.1	15.7	14.0	12.0	10.7	8.8	36
38				26.9	23.8	21.6	18.5	15.1	13.6	11.6	10.5	8.8	38
40				25.3	22.5	21.3	18.3	14.6	13.1	11.1	10.1	8.8	40
42				25.0	21.3	20.9	17.9	14.2	12.7	10.8	9.8	8.8	42
44					20.3	20.4	17.2	13.8	12.4	10.4	9.4	8.8	44
46					19.4	19.9	17.0	13.7	12.0	10.0	9.3	8.8	46
48					19.0	19.2	16.8	13.5	11.6	9.6	9.2	8.8	48
50						18.0	16.4	13.4	11.3	9.3	9.0	8.8	50
52							15.6	13.2	11.0	9.0	8.7	8.8	52
54							14.8	13.1	10.8	8.7	8.7	8.8	54
56							14.0	13.0	10.5	8.5	8.4	8.6	56
58							13.3	12.5	10.2	8.2	8.2	8.2	58
60								11.8	9.9	8.1	8.0	7.9	60
62								11.2	9.8	7.9	7.6	7.6	62
64								10.2	9.6	7.8	7.6	7.5	64
66									9.5	7.6	7.4	7.2	66
68									9.1	7.5	7.1	7.1	68
70									8.2	7.3	6.5	6.8	70
72										7.2	6.1	6.7	72
74										7.1	5.8	6.5	74
76										6.9	5.3	6.4	76
78											5.3	6.3	78
80												6.0	80
82												5.7	82
84												5.6	84
86												5.3	86
⚡	5	4	4	3	3	3	2	2	2	2	1	1	⚡

Load Chart - Telescopic Boom + Luffing Jib + Superlift Device (TSL)

性能表 - 主臂 + 变幅副臂 + 超起

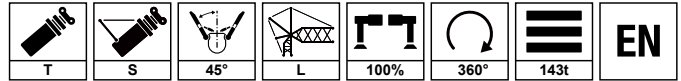

Unit: t

Luffing Jib m	50.7m												Luffing Jib m
	18m	24m	30m	36m	42m	48m	54m	60m	66m	72m	78m	84m	
16	49.8												16
18	46.7	42.0											18
20	44.6	41.3	34.2										20
22	43.9	41.0	32.8	29.0									22
24	42.2	40.4	32.1	29.0	25.3								24
26		39.8	31.6	29.0	25.3	23.0							26
28		37.5	31.0	28.0	25.3	22.2	19.7						28
30		34.5	30.5	27.1	24.2	21.2	19.2	16.4					30
32			29.5	26.1	23.8	21.4	18.3	16.2	13.1				32
34			27.2	25.6	23.2	20.8	17.6	15.1	12.6	10.2			34
36			25.6	24.4	22.9	20.2	16.9	14.7	12.3	10.0	9.1		36
38				23.4	22.3	19.7	15.9	14.4	11.9	9.8	8.8	8.2	38
40				22.3	21.4	19.2	15.4	13.9	11.6	9.5	8.6	8.2	40
42				21.1	20.3	18.9	15.2	13.7	11.2	9.2	8.3	8.2	42
44				20.8	19.3	18.6	14.9	13.2	10.9	9.0	8.0	8.2	44
46					18.5	18.2	14.4	12.7	10.6	8.7	7.8	8.2	46
48					17.7	17.7	14.2	12.2	10.3	8.4	7.6	8.2	48
50						17.1	14.0	12.1	10.0	8.1	7.5	8.2	50
52						16.1	13.7	11.9	9.8	7.9	7.4	8.2	52
54							13.1	11.8	9.5	7.7	7.2	7.9	54
56							12.5	11.6	9.4	7.5	7.2	7.5	56
58							11.8	11.5	9.1	7.4	6.9	7.2	58
60							11.2	11.4	8.9	7.1	6.8	6.9	60
62								10.9	8.7	7.0	6.6	6.8	62
64								9.8	8.6	6.9	6.3	6.5	64
66								9.6	8.4	6.8	6.3	6.4	66
68									8.4	6.7	6.1	6.1	68
70									8.0	6.6	5.8	6.0	70
72									7.4	6.5	5.4	5.8	72
74										6.4	5.1	5.7	74
76										6.3	4.8	5.6	76
78										6.2	4.6	5.3	78
80											4.4	5.0	80
82												4.9	82
84												4.6	84
86													86
⚡	5	4	3	3	2	2	2	2	1	1	1	1	⚡

Load Chart - Telescopic Boom + Luffing Jib + Superlift Device (TSL)

性能表 - 主臂 + 变幅副臂 + 超起

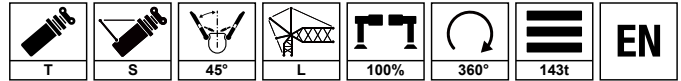

Unit: t

Jib height m	56.3m												Jib height m	
	18m	24m	30m	36m	42m	48m	54m	60m	66m	72m	78m	84m		
16	43.0												16	
18	40.4	36.0											18	
20	38.6	35.4	30.3										20	
22	37.9	35.1	29.1	25.7									22	
24	36.5	34.6	28.5	25.7	22.5								24	
26		34.1	28.0	25.7	22.0	19.4							26	
28		32.1	27.5	24.9	21.0	18.8							28	
30		29.5	27.0	24.2	20.2	18.0	17.1						30	
32			26.2	23.3	19.9	18.2	16.7	14.6	11.1				32	
34			24.1	22.8	19.4	17.7	16.0	14.4	10.7	7.9			34	
36			22.8	21.9	19.1	17.2	15.4	13.3	10.4	7.7			36	
38				21.0	18.6	16.7	14.9	13.0	10.1	7.6	7.0		38	
40				20.1	17.9	16.3	14.0	12.7	9.8	7.4	6.8	6.4	40	
42				19.0	17.0	16.1	13.6	12.2	9.5	7.1	6.6	6.4	42	
44				18.8	16.3	15.8	13.5	12.0	9.2	7.0	6.4	6.4	44	
46					15.6	15.5	13.2	11.6	9.0	6.7	6.2	6.4	46	
48					15.0	15.1	12.8	11.1	8.8	6.5	6.0	6.4	48	
50						14.6	12.7	10.7	8.5	6.3	5.9	6.4	50	
52						13.8	12.5	10.6	8.3	6.2	5.8	6.4	52	
54							12.3	10.5	8.1	6.0	5.8	6.3	54	
56							11.8	10.3	8.0	5.9	5.6	6.1	56	
58							11.2	10.2	7.8	5.8	5.6	5.8	58	
60							10.7	10.1	7.6	5.6	5.4	5.6	60	
62								10.2	9.9	7.4	5.6	5.3	62	
64									9.5	7.3	5.5	5.1	64	
66									8.5	7.2	5.4	4.9	66	
68									8.3	7.1	5.4	4.9	68	
70										6.8	5.3	4.7	70	
72										6.3	5.2	4.6	72	
74											5.1	4.2	74	
76											5.1	4.0	76	
78											5.0	3.8	78	
80												3.7	80	
82												3.5	82	
84													3.9	84
86													3.7	86
吊钩	4	4	3	3	2	2	2	2	1	1	1	1	吊钩	

Load Chart - Telescopic Boom + Luffing Jib + Superlift Device (TSL)

性能表 - 主臂 + 变幅副臂 + 超起

Unit: t

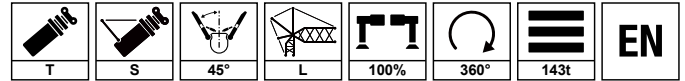

m	61.9m							67.5m							m
	18m	24m	30m	36m	42m	48m	54m	18m	24m	30m	36m	42m	48m		
18	37.5							32.8						18	
20	35.2	31.8						30.8	27.4					20	
22	33.6	31.3	26.8					29.4	27.0					22	
24	33.0	31.0	25.7	21.9				29.0	26.8	23.4				24	
26	31.8	30.6	25.2	21.9	19.0				26.4	22.5	17.0			26	
28		30.2	24.8	21.9	18.2	16.8			26.0	22.0	16.3	17.0		28	
30		28.4	24.3	21.2	17.4	16.3	14.9		24.5	21.7	15.8	16.3	14.3	30	
32		26.1	23.9	20.6	16.7	15.6	14.7		22.5	21.3	15.3	15.6	13.8	32	
34			23.2	19.9	16.5	15.7	14.2			20.9	14.9	15.1	13.3	34	
36			21.4	19.5	16.1	15.3	13.9			20.3	14.4	14.9	13.4	36	
38			20.2	18.7	15.9	14.9	13.6			18.7	14.1	14.5	13.1	38	
40				18.0	15.5	14.5	13.0			17.7	13.5	14.3	12.7	40	
42				17.3	14.9	14.2	12.7				13.0	14.0	12.4	42	
44				16.4	14.2	14.0	12.8				12.5	13.5	12.1	44	
46					13.6	13.7	12.7				11.8	12.9	12.0	46	
48					13.1	13.5	12.4					12.4	11.8	48	
50						13.1	12.4					11.9	11.6	50	
52						12.7	11.1						11.3	52	
54						12.0	10.8						10.9	54	
56							10.4						10.4	56	
58							10.0							58	
60							9.5							60	
62							9.1							62	
64														64	
66														66	
68														68	
70														70	
72														72	
74														74	
76														76	
78														78	
80														80	
82														82	
T	4	3	3	2	2	2	2	3	3	2	2	2	2	T	



SANY GROUP CRANE BU

SANY Mobile Crane Industrial Park, No.168 Jinzhou Avenue, Jinzhou Development Zone, Changsha City,
Hunan Province, P.R. China Zip 410600
Consulting sanycrane@sanygroup.com (Crane BU) / crd@sany.com.cn (IHQ)
After-sales Service 0086-400 6098 318

Reminder:

Any change in the technical parameters and configuration due to product modification or upgrade may occur without prior notice.
The machine in the picture may include additional equipment. This brochure is for reference only, and goods in kind shall prevail.
Copyright at SANY. No part of this brochure may be copied or used for any purpose without written approval from SANY.

© Edited in September 2023

三一集团起重事业部

中国湖南长沙金洲开发区金洲大道 168 号 三一汽车起重机产业园 邮编: 410600
咨询: sanycrane@sanygroup.com (起重事业部) / crd@sany.com.cn (国际总部)
海外售后服务: 0086-400 6098 318

温馨提示:

由于技术不断更新, 技术参数及配置如有更改, 恕不另行通知。图中机器可能包括附加设备, 本画册仅供参考, 以实物为准。
版权为三一所有, 未经三一书面许可, 本画册任何内容不得被复制用于任何目的。

© 2023 年 9 月版

