

**SANY**<sup>®</sup>

CE

# SPECIFICATION



 70t

 50m

 66.5m

# SAC700E

SANY ALL TERRAIN CRANE

QUALITY CHANGES THE WORLD

[www.sanyglobal.com](http://www.sanyglobal.com)

V1.0

It is one of the core business units in SANY Group, specializing in the development and manufacturing of high-end wheel cranes, crawler cranes and tower cranes, including the complete range of wheel cranes from 8 to 2400t, crawler cranes from 25 to 4500t and tower cranes from 6 to 185t.

三一集团旗下核心事业部，从事高端轮式起重机、履带起重机、塔式起重机系列产品的研发制造。覆盖8-2400吨全吨位轮式起重机，25-4500吨全吨位履带起重机，6-185吨塔式起重机。



SANY CRANE



# SAC700E

SANY ALL TERRAIN CRANE  
70T LIFTING CAPACITY

SAC700E is an all-terrain crane with 70t lifting capacity, 6 section 50m boom, wireless remote control of all motions, optional anti-electromagnetic interference module, and the brand-new iCab, with driving and operation comfort fully upgraded.

一款最大起重量70吨、6节臂、最大臂长50米的全地面起重机，作业动作可以实现无线遥控，标配抗电磁干扰模块，配备全新上下驾驶室——iCab，驾驶、操作舒适度全面升级。



## 50m boom

Boom full extension 50m

50m主臂

主臂全伸最长 50m

## Wireless remote control

Wireless remote control available for all actions

无线遥控

整车动作全部实现无线遥控



## **Anti-electromagnetic interference**

An anti-electromagnetic interference module adopted, enabling well functioning under strong electric and magnetic conditions (excluding wireless operations)

抗电磁干扰

通过抗电磁干扰模块可以在强电强磁下的正常工作  
(不含无线操作)

## **All new iCab design**

Ergonomic concept of safety and comfort

全新两室

操作安全、舒适、人机工程全面升级



## New Generation Cab Capacious, Convenient and Comfortable

全新操纵室  
操作便捷、宽敞舒适

## iCab

Driver's cab 新两室 - 下车

- Multi-function seat with air suspension, making driving more comfortable
- Double seats and foldable berth for the co-driver
- 10.1-inch touch screen integrated with back-up image and multi-media
- Electric rearview mirror with electric heating, ensuring good field of view in foul weather
- Adjustable high-brightness LED headlamps/fog lamps, providing clear vision at night
- Reversing sensor with accurate distance detection capability, fully covering the parking area without blind spots, and effectively avoiding scratch and collision
- Full-automatic HVAC, able to automatically adjust indoor temperature as demanded

- 主驾驶位配备气浮多功能座椅, 驾驶更舒适
- 副驾驶位设置双座椅可折叠式卧铺
- 12.1英寸触摸大显示屏, 集成倒车影像、语音娱乐功能
- 电动、电加热后视镜, 不惧恶劣冰雪天气
- 高亮度可调节 LED 大灯 / 雾灯, 夜间视野清晰
- 全自动冷暖空调, 自动根据需求调整室内温度

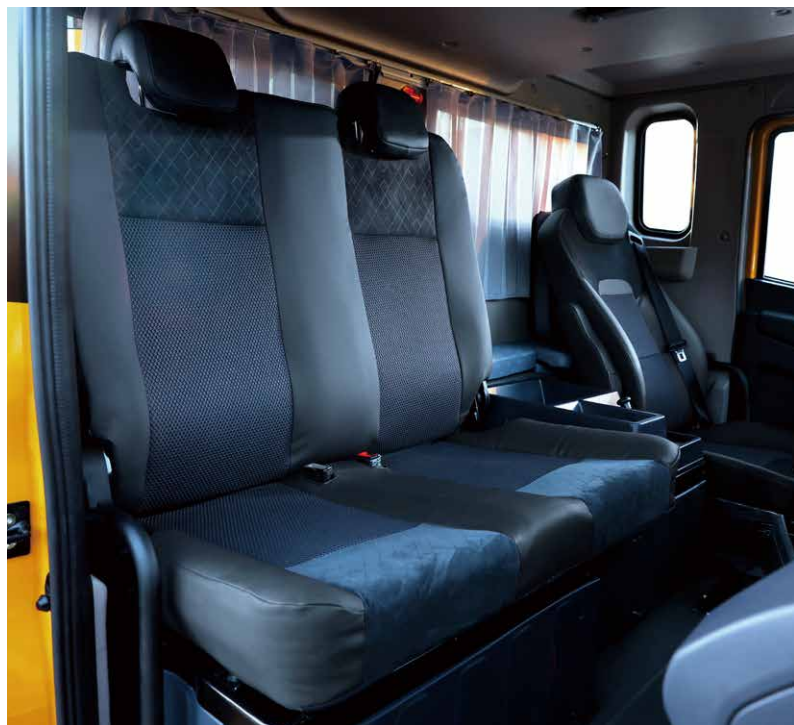

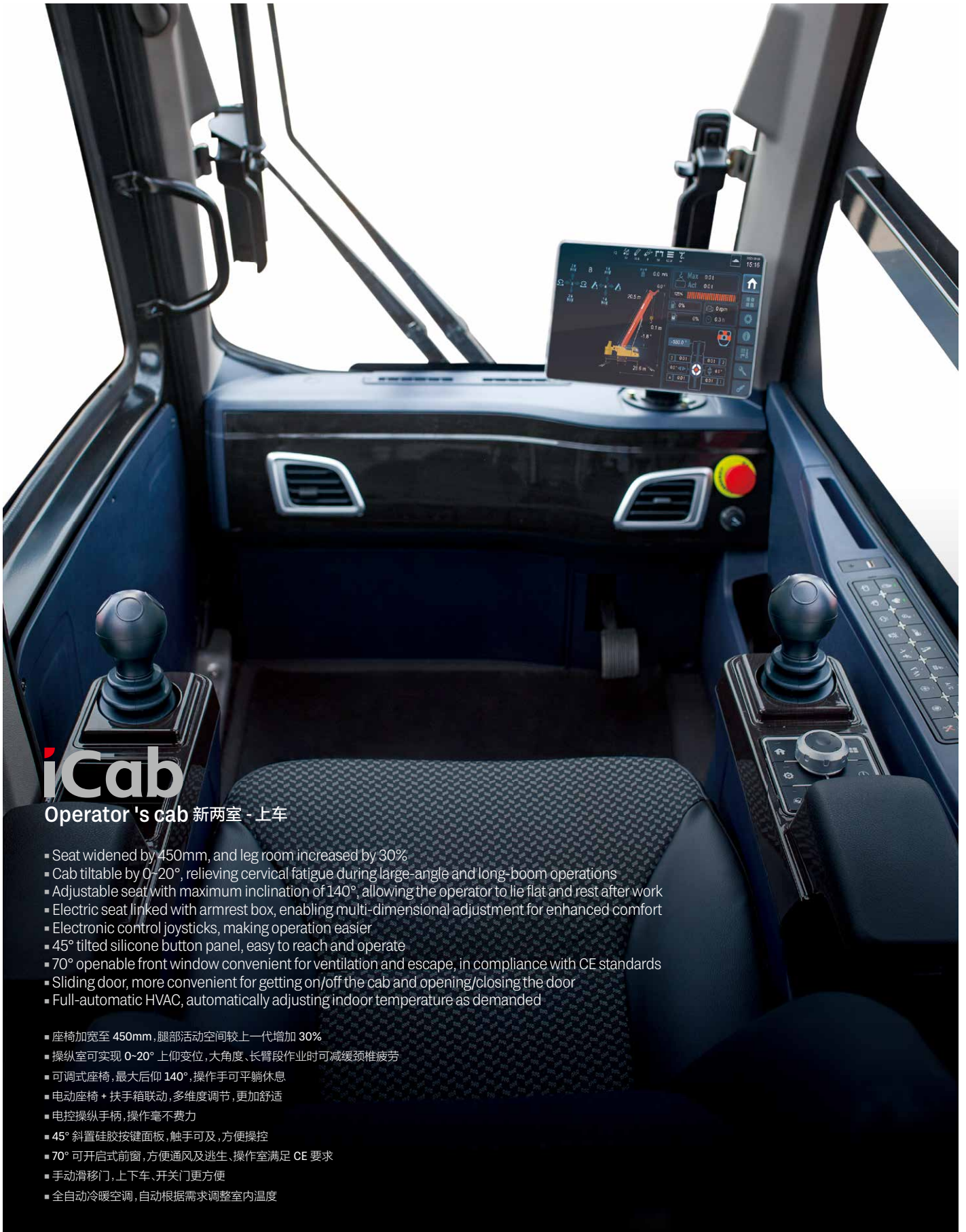

# iCab

## Operator's cab 新两室 - 上车

- Seat widened by 450mm, and leg room increased by 30%
- Cab tiltable by 0-20°, relieving cervical fatigue during large-angle and long-boom operations
- Adjustable seat with maximum inclination of 140°, allowing the operator to lie flat and rest after work
- Electric seat linked with armrest box, enabling multi-dimensional adjustment for enhanced comfort
- Electronic control joysticks, making operation easier
- 45° tilted silicone button panel, easy to reach and operate
- 70° openable front window convenient for ventilation and escape, in compliance with CE standards
- Sliding door, more convenient for getting on/off the cab and opening/closing the door
- Full-automatic HVAC, automatically adjusting indoor temperature as demanded

- 座椅加宽至 450mm, 腿部活动空间较上一代增加 30%
- 操纵室可实现 0-20° 上仰变位, 大角度、长臂段作业时, 可减缓颈椎疲劳
- 可调式座椅, 最大后仰 140°, 操作手可平躺休息
- 电动座椅 + 扶手箱联动, 多维度调节, 更加舒适
- 电控操纵手柄, 操作毫不费力
- 45° 斜置硅胶按键面板, 触手可及, 方便操控
- 70° 可开启式前窗, 方便通风及逃生, 操作室满足 CE 要求
- 手动滑移门, 上下车、开关门更方便
- 全自动冷暖空调, 自动根据需求调整室内温度

## Anti-electromagnetic Interference 抗电磁干扰

Anti-electromagnetic interference module, allowing the crane to work normally in strong electric field or strong magnetic field ( $\leq 20\text{V/m}$  and  $> 500\text{m}$  away from interference source), including cluster construction of high-power equipment, and the vicinity of multiple interference sources including high-voltage lines, broadcasting base stations, power plants, aluminum plants, radar stations, military bases or mobile communication stations.

配备抗电磁干扰模块, 实现在磁场强度不大于  $20\text{V/m}$ 、距干扰源  $500$  米范围外的强电场、强磁场, 如大功率设备集群化施工, 紧邻高压线、广播基站、电厂、铝厂、雷达基站、军事基地或移动设备等通信基站附近多个干扰源的环境中正常工作。



## Wireless Remote Control System 无线遥控系统

### Main functions

Outrigger control - single-piece / single-side outrigger beam and jack telescoping in/out, and one-button leveling.

Crane operation - boom telescoping, luffing, slewing, hoisting.

Auxiliary action control - counterweight lifting/lowering, jib pushing/pulling, side step extension/retraction, cab tilting, etc.

### 主要功能

支腿控制——单个和单边支腿水平伸缩、垂直起落, 并支持一键调平。

上车作业——实现伸缩臂、起落幅、回转、卷扬收放绳。

辅助动作操作——配重起落、副臂推拉、踏板伸缩、操作室变位等辅助操作。

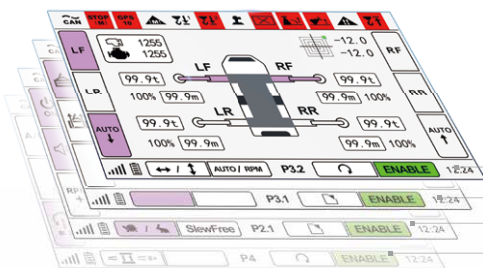

- Outrigger status 支腿界面
- Counterweight lifting/lowering, step extension/retraction 配重起落、踏板伸缩
- Main parameters 主参数展示界面
- Boom telescoping 起重臂伸缩界面



## Working Condition

### 工况组合

#### T: Boom 主臂

Max. lifting capacity 最大起重量	70t
Max. boom length 最大臂长	50m
Max. radius 最大幅度	40m
Max. height 最大高度	50.5m

#### TA: Boom + auxiliary jib (optional) 主臂 + 鹅头臂(选配)

Max. lifting capacity 最大起重量	9.1t
Max. boom + jib length 最大臂长	53m
Max. radius 最大幅度	40m
Max. height 最大高度	53.5m

#### THJ: Boom + hydraulically adjustable jib (optional) 主臂 + 液压(机械)变幅副臂(选配)

Max. lifting capacity 最大起重量	8t
Max. boom + jib length 最大臂长	66m
Max. radius 最大幅度	44m
Max. height 最大高度	66.5m



# Travel Flexibility

## 通过能力



On-road driving 公路行驶



All-wheel steering 全轮转向



Crab steering 蟹行



Reduced swing-out steering 无偏摆转向



Independent rear axle steering 独立后桥转向



Independent front axle steering 后桥锁定转向

### Traveling with counterweight and hook block on board

带载行驶能力



≤12t ≤12t ≤12t ≤12t

☰ CW 10.8t



≤16t ≤16t ≤16t ≤16t

☰ CW 15t

## Carrier Frame

### 车架底盘

#### High strength frame

Carrier frame welded with fine grain high-strength steel plates of box-type section, providing a stronger anti-torsion capability than C-type or H-type construction.

#### Stable support

H-type outriggers of 4-point support, which is of same material and design as frame, and helps improve the stability of operation.

#### 高强车架

车架采用细晶粒高强度钢板焊接而成,主截面采用抗扭的箱型结构,相比 C 型和工字型结构抗扭矩能力更强。

#### 稳定支腿

与车架采用相同的材质及设计结构,使用传统的“H”型 4 点支撑布置,确保作业稳定性。

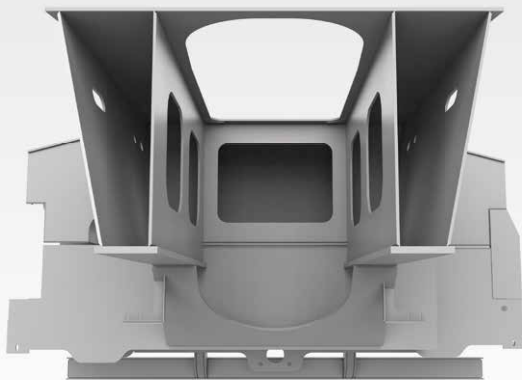

# Power Train

## 动力系统

### Chassis engine

Mercedes-Benz OM471LA off-road in-line six cylinder water-cooled diesel engine, complying with EU Stage III or EU Stage V emission standards.  
 Rated power: 360kW/1600rpm.  
 Max. torque: 2400Nm/1300rpm.  
 Fuel reservoir capacity: 430L.

### Transmission

ZF Traxon AT.

### Braking system

Braking system consisting of Knorr disc brake, WABCO air chamber and WABCO ABS, more reliable and efficient. Telma eddy current retarder, allowing for effective assist braking, reducing the wear of axle brake linings and prolonging service life. Parking brake and service brake equipped for axles 1, 2, 3.

### Axles and suspension

Kessler axles with high bearing capacity and reliable quality. Hydro pneumatic suspension system with stroke of -100/+100mm.  
 Standard 8 × 6, with axles 1, 3, 4 driven.

### Steering system

Bosch dual-circuit power steering gear, with all axles steered.

### 底盘发动机

奔驰OM471LA非道路直列6缸水冷柴油机，可满足欧五排放法规要求。  
 额定功率：360kW/1600rpm。  
 最大扭矩：2400Nm/1300rpm。  
 燃油箱容积：430L。

### 变速箱

ZF Traxon 自动变速箱。

### 制动系统

由 Knorr 盘式制动器，WABCO 制动气室，WABCO ABS 主要配件系统组成，制动性能更加可靠、高效。可有效进行辅助制动，减少车桥制动片磨损，提高制动片使用寿命。

### 车桥悬架

Kessler 车桥，承载能力强，质量可靠。采用油气悬挂系统，悬挂行程 -100/+100mm。  
 标配 8 × 6 驱动模式，1、3、4 桥为驱动桥。

### 转向系统

Bosch 双回路助力转向器，双回路转向助力系统，全轮转向。

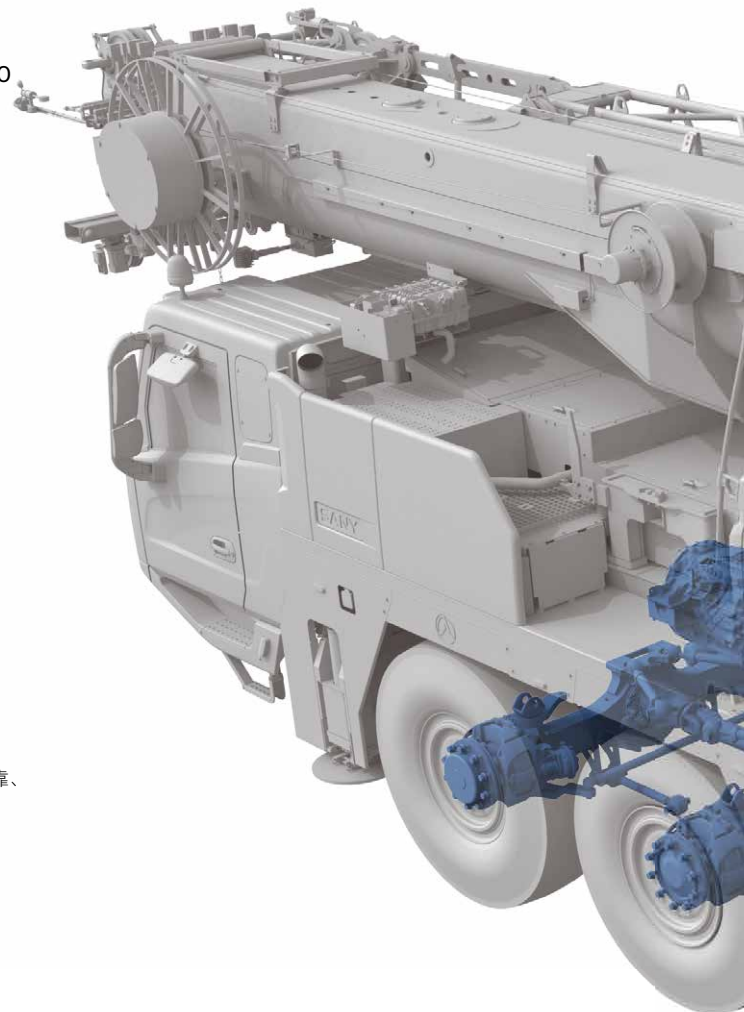

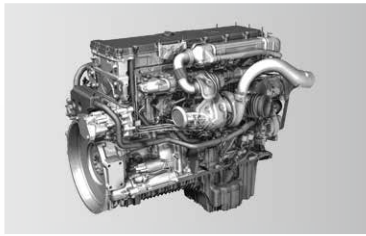

 Mercedes-Benz

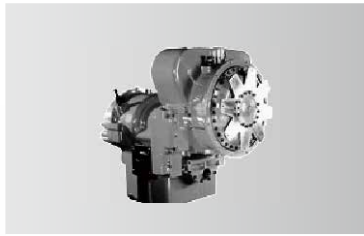





**KESSLER-CO**

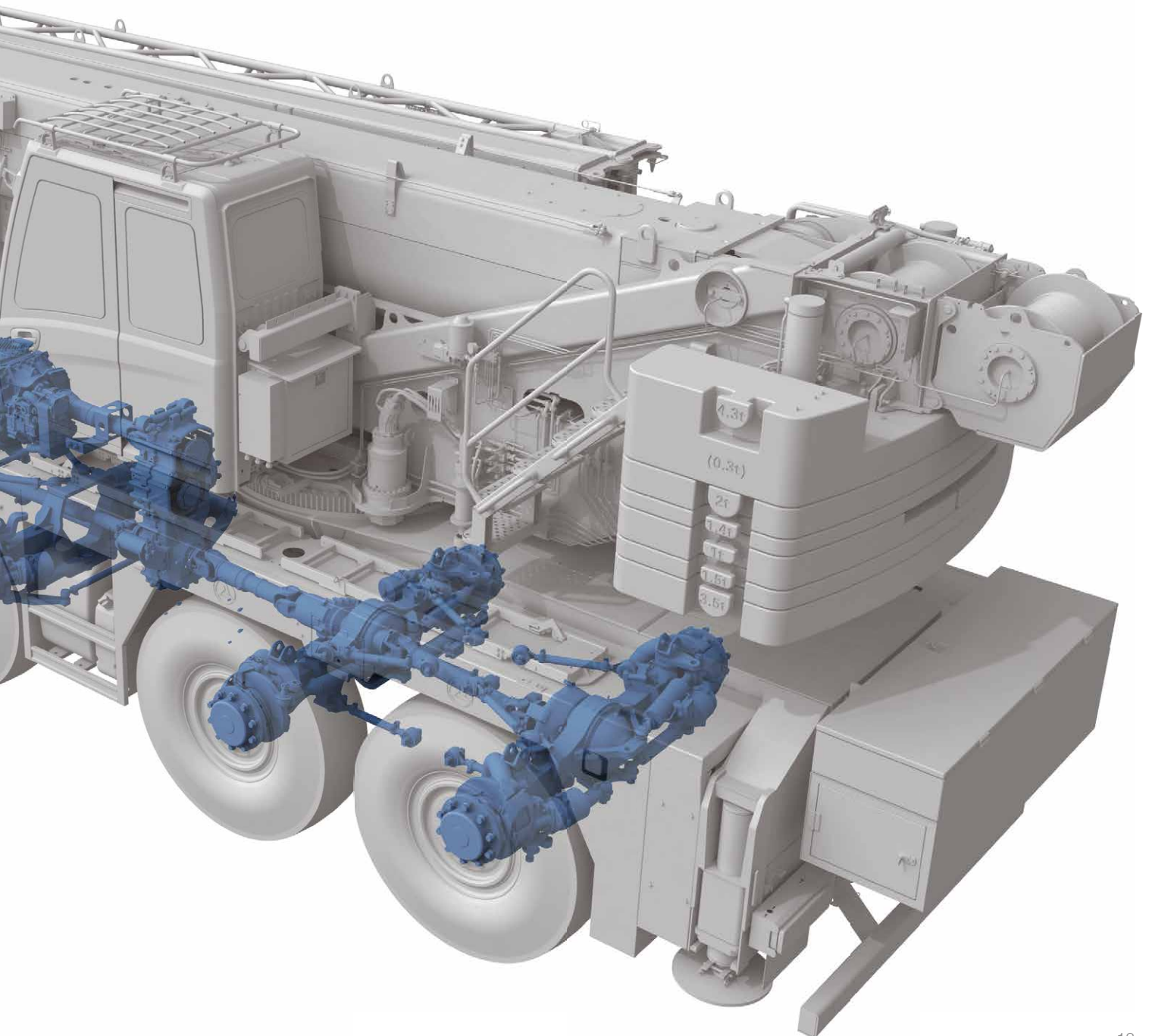

# Electrical System

## 电气系统

### Smart CAN-BUS communication system

International advanced CAN-BUS data communication network. The entire vehicle adopts a safety controller (compliant with EU EN13000 standards, redundant design, with built-in fault diagnosis).

### Car-level central control screen

A 12.1-inch touchscreen display integrated with reverse image and entertainment functions.

### Precise load moment indicator

SANY independently developed high-precision LMI, with an accuracy of 0~5%.

### Cabling

Centralized junction box and heavy-duty connector applied for cabling of superstructure, convenient for maintenance; IP rating up to IP67, ensuring high reliability.

### Winch monitoring system

Winch cameras equipped for monitoring its working condition and identifying rope disorder in time.

### Integrated bus button panel input

Various operating states displayed by button indicator lights, and one-button multi-functional operation realizable by writing various operation modes.

### 智能总线通信系统

国际先进的分布式集成总线数据通信网络。整车采用安全控制器（符合欧盟EN13000标准，冗余设计，自带故障诊断）。

### 车规级中控屏

12.1英寸触摸大显示屏，集成倒车影像、娱乐功能。

### 精准力限器系统

三一自主研发的力矩限制器系统，精度达0~5%。

### 电缆布线

上车电缆布线采用集中式分线盒及重载接插件，维护方便；防护等级IP67，可靠性高。

### 卷扬监控系统

卷扬摄像头监视卷扬工作及时发现乱绳的情况。

### 集成总线按键面板输入

可通过按键指示灯显示各种工作状态，通过写入多种操作模式实现一键多功能。



Anti-two-block switch  
高度限位器



Third wrap indicator  
三圈保护器



Cable reel  
电缆卷筒



Cable reel inside the boom  
臂内卷筒



Anemometer  
风速仪

# MachineLink+

ROOTCLOUD T-AMS Pro device comes as standard to realize GPS trajectory, machine status, maintenance management, alarm management on computer or mobile MachineLink+ platform, by remote control of cranes. This telematics package greatly boosts efficiency of customer fleet management and helps provide better after-sales services.

标配树根物联终端 T-AMS Pro, 通过对起重机设备的远程控制, 在电脑或移动端 MachineLink+ 平台实现轨迹回放、设备状态、维保设备、报警管理等功能, 极大提高客户设备管理效率, 提升三一售后服务能力。



## Hydraulic System 液压系统

### Single cylinder pin

6 boom sections of variable length combinations, realizing higher lifting capacity at larger radius; automatic telescoping, time saving and labor saving.

### 单缸插销系统

含 6 节主臂, 大臂间彼此独立, 可实现更多臂段组合, 为长臂段、大幅度状态下提供更大吊载能力, 可自动伸缩, 省时省力。

# Superstructure

## 上车

Open-type electronically controlled load-sensing system and closed-type slewing system, enabling combined operation of four actions at the same time.

Electro proportional compensated passive luffing-down system applied to control the luffing speed, making luffing more reliable and stable.

Closed-type slewing system, ensuring no pressure loss and no overflowing noise upon start/stop, and making the operation quieter and more energy-saving.

Electronically controlled load-sensing hydraulic system, electronic joystick and electronic throttle, ensuring easy operation and more accurate control and millisecond-level action response speed, with min. single-rope hoisting speed  $\leq 1\text{m}/\text{min}$ .

通过开式电控负载敏感系统和闭式回转系统,可同时实现四动作联动。

电比例自重落幅系统控制落幅速度,更可靠更平稳。

采用闭式回转系统,停启时无压力损失,无溢流噪声,更安静,更节能。

电控负载敏感液压系统,采用电手柄、电油门控制,轻松操作的同时,控制更精准;动作响应毫秒级速度;卷扬单绳最低速度  $\leq 1\text{m}/\text{min}$ ;复合动作分配误差  $\leq 8\%$ 。

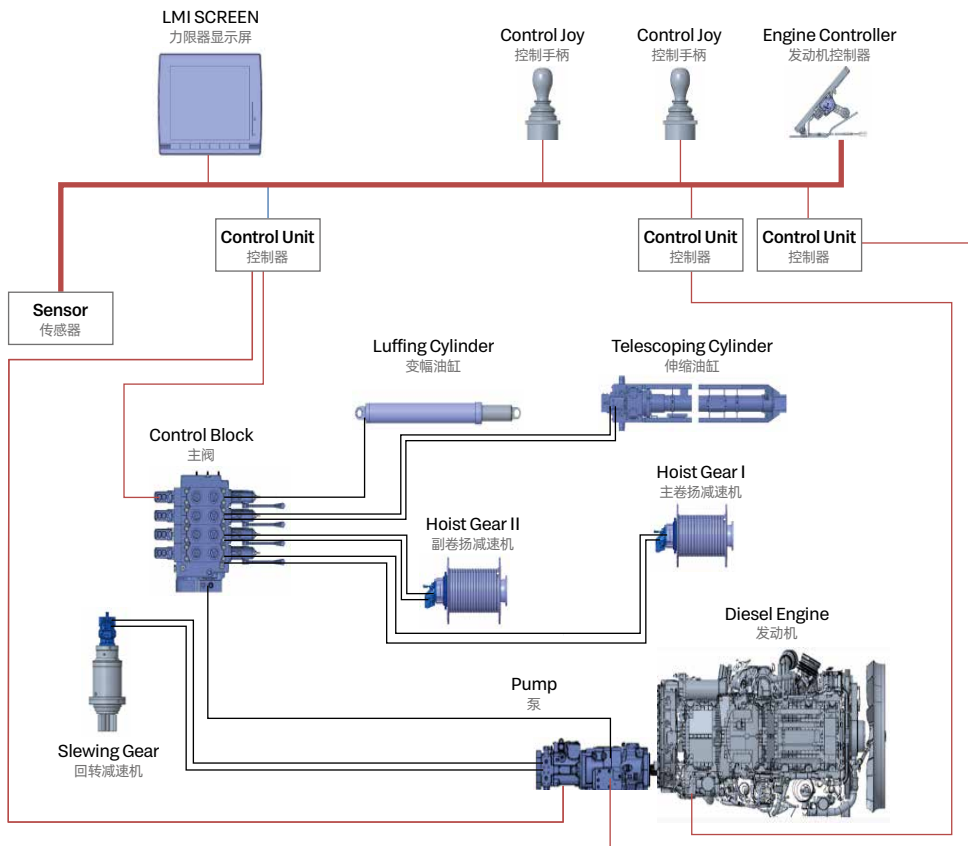



# Chassis

## 下车

### Dual circuit + emergency main steering system

Main steering system: Dual oil pump directly connected to the engine to supply oil independently to the steering gear, ensuring efficient and reliable steering.

Emergency steering system: A bidirectional piston pump installed on the transfer case, ensuring steering assistance throughout the traveling.

### Electro-hydraulic assisted steering system

A load-sensing piston pump installed to supply oil for assisted steering, which is directly connected to the engine and always in the standby mode, so that the assisted steering system can respond quickly once the assisted steering command is received.

### Suspension system

A piston pump adopted as the power source of suspension system, and suspension modes electrically controlled to realize normal driving and driving with CW on board with suspension locked.

### Outrigger telescoping system

Full-electric control of outrigger, auto leveling available.

### 双回路+应急主转向系统

主转向系统：双联油泵与发动机直连，独立对方向机供油，主转向高效、可靠。

应急转向系统：采用力士乐双向柱塞泵，安装在分动箱上，确保车辆行进过程中始终有转向助力。

### 电液辅助转向系统

辅助转向采用力士乐负载敏感柱塞泵提供油源，该油泵与发动机直连，油泵始终处于转向往机模式，一旦接到辅助转向指令，辅助转向系统能够快速响应。

使用大容量蓄能器作为备用能源，在失去动力的情况下，可以做到有限次数的正常辅助转向。

### 悬挂系统

悬挂系统采用力士乐柱塞泵作为动力油源，操作方式采用电控，通过选择不同的悬挂模式可以实现正常行驶和锁定模式下的带载行驶；在起重机上车作业时能够对悬挂进行锁定。

### 支腿伸缩系统

支腿伸缩采用全电控方式，可实现支腿的无级伸缩，电控模式下可实现整车自动调平。

# Overall Dimensions

## 整机尺寸

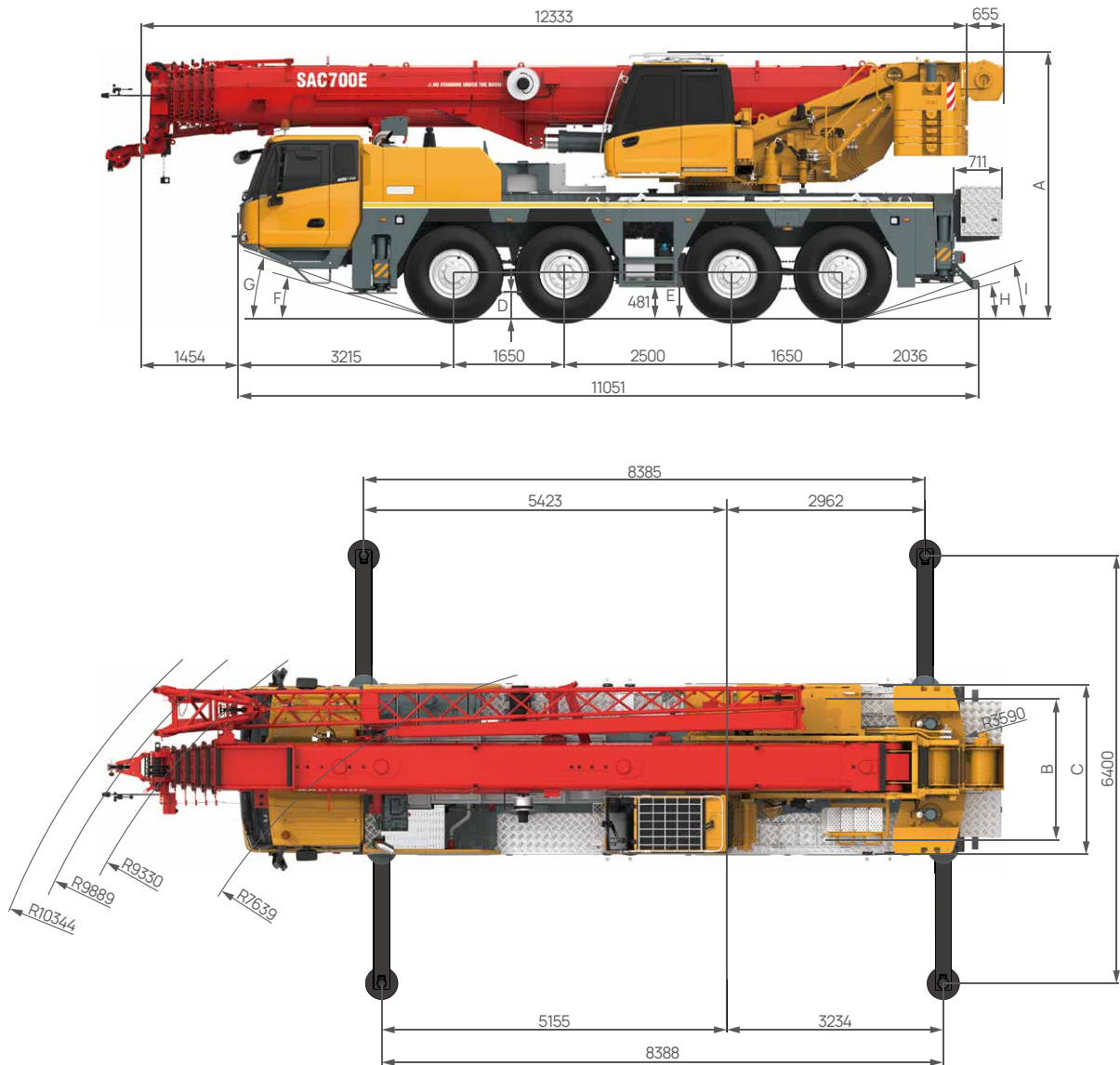

Tire size 轮胎尺寸	A	A*	B	C	D	E	F	G	H	I
Unit 单位	mm	mm	mm	mm	mm	mm	°	°	°	°
385/95 R25	3927	3827	2170	2550	342	634	14	19	14	19
445/95 R25	3985	3885	2100	2550	392	684	15	20	15	20
525/80 R25	3985	3885	2260	2790	392	684	15	20	15	20

Remark: A column is calculated when suspension is at middle level. A\* column is calculated when suspension is at lowest level.  
 备注: A 列为悬挂处于中位, A\* 列为悬挂处于最低位。

# Technical Specification

## 整机参数

CATEGORY 类型	ITEM 项目	UNIT 单位	VALUE 参数	
CAPACITY 额定起重量	Max. lifting capacity 最大起重量	t	70	
WEIGHT 重量	Gross weight 整机总质量	kg	48000	
POWER (CHASSIS) 发动机参数 (下车)	Engine model 发动机型号 (排放标准)	-	Benz OM471LA.E5-2	
	Max. engine power 发动机最大功率	kW/rpm	360	
	Max. engine torque 发动机最大输出扭矩	N·m/rpm	2400/1300	
DIMENSIONS 尺寸参数	Overall length 整机全长	mm	12333	
	Overall width 整机全宽	mm	2550	
	Overall height 整机全高	mm	4000	
TRAVEL 行驶参数	Max. travel speed 最高行驶速度	km/h	80	
	Steering radius 转弯半径	Min. steering radius 最小转弯半径	m	7.6
		Min. steering radius of boom tip 臂头最小转弯半径	m	10.3
	Wheel formula 车轮模式	-	8×6×8	
	Min. ground clearance 最小离地间隙	mm	278	
	Approach angle 接近角	°	15	
	Departure angle 离去角	°	19	
	Max. gradeability 最大爬坡度	-	62%	
	Fuel consumption per 100km 每100公里油耗	L	55	
MAIN PERFORMANCE 主要性能参数	Working temperature range 使用温度区间	℃	-20~+45	
	Min. rated lifting radius 最小额定幅度	m	3	
	Tail slewing radius 转台尾部回转半径	m	3.6	
	Boom sections (Qty.) 臂节数	-	6	
	Boom shape 臂形状	-	U shape U型	
	Max. lifting moment 最大起重力矩	Basic boom 基本臂	kN·m	2142
		Full-extension boom 全伸主臂	kN·m	1066
		Full-extension boom + jib 全伸主臂 + 副臂	kN·m	532
	Boom length 臂长	Basic boom 基本臂	m	11
		Full-extension boom 全伸主臂	m	50
		Full-extension boom + jib 全伸主臂 + 副臂	m	66
	Max. lifting height 最大起重高度	Basic boom 基本臂	m	11.5
		Full-extension boom 全伸主臂	m	50.5
Full-extension boom + jib 全伸主臂 + 副臂		m	66.5	
Outrigger span (Longitudinal × Transverse) 支腿跨距 (纵 × 横)	m	8.4 × 6.4		
Jib offset 副臂安装角度	°	0, 20, 40		
AIRCONDITIONER 空调	In operator's cab 上车空调	-	Heating & Cooling 制冷、制热	
	In driver's cab 下车空调	-	Heating & Cooling 制冷、制热	

# Technical Specification

## 整机参数



Axle Load 轴荷

Axle 轴	1	2	3	4	Gross weight 总重量
Axle load 轴荷 /t	12	12	12	12	48



Hook 吊钩

Rated load 额载 /t	Number of sheaves 滑轮数量	Rope rate 倍率	Hook weight/kg 吊钩重量
63 ○	7	15	463
50 ○	5	11	406
32 ●	3	7	323
16 ○	1	3	215
6.3 ●	-	1	108

● Standard 标配 ○ Optional 选配



Operations 主要动作参数

Item 项目	Max.single rope lifting speed (empty load) 单绳速度 (空载)	Rope diameter/length 钢丝绳直径 / 长度	Max. single line pull 最大单绳拉力
Main winch 主卷扬	0-120m/min	Φ15mm/230m	45kN
Auxiliary winch 副卷扬	0-120m/min	Φ15mm/220m	45kN
Slewing speed 回转速度	1.2r/min		
Full luffing up/down time of boom 主臂起落幅时间	70s/90s		
Full extension/retraction time of boom 主臂伸缩时间	350s/350s		
Outrigger jack 垂直支腿	Extension 伸	25s	
	Retraction 缩	35s	
Outrigger beam 水平支腿	Extension 伸	35s	
	Retraction 缩	35s	

# Counterweight Combinations

## 配重组合

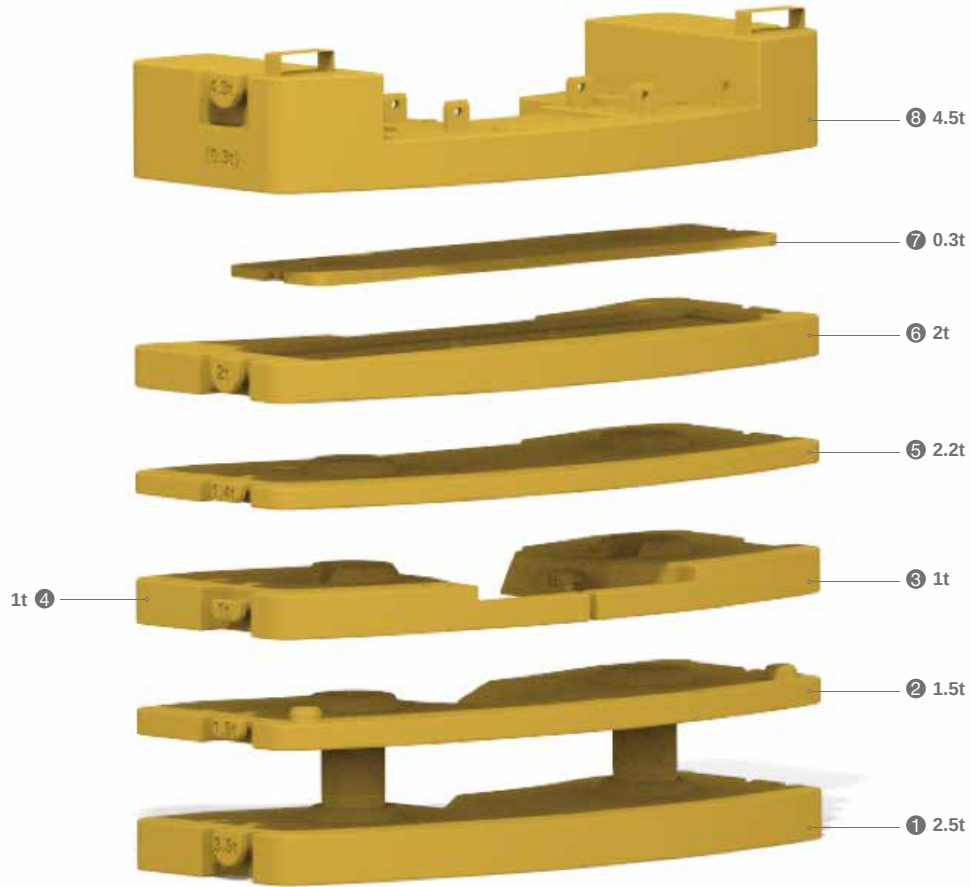

Total weight 总重量	①	②	③	④	⑤	⑥	⑦	⑧
	2.5t	1.5t	1t	1t	2.2t	2t	0.3t	4.5t
4.5t								•
6.8t						•	•	•
9.3t	•					•	•	•
10.8t	•	•				•	•	•
12.8t	•	•	•	•		•	•	•
15t	•	•	•	•	•	•	•	•

# Transport Dimensions

## 运输尺寸

Unit:mm

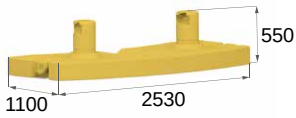

2.5t

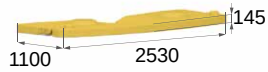

1.5t

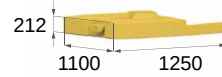

1t

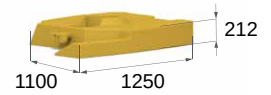

1t

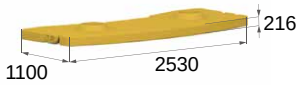

2.2t

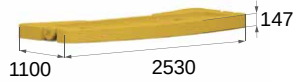

2t



0.3t

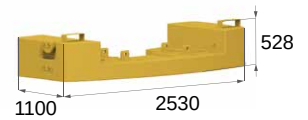

4.5t

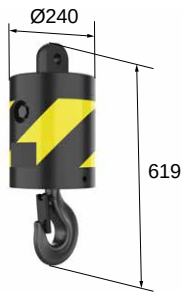

6.3t hook block



32t hook block



16t hook block



50t hook block



63t hook block

# Crane Introduction

## 整机介绍

### Driver's cab 驾驶室

- Entry through two opposing doors, three seats with a folding berth. It's soundproofing performance meets the standard of heavy duty trucks. Air suspension seat features shock absorption, back adjustment, lumbar support and other ergonomic designs. Virtual LCD instrument and 12.1" console screen integrate auto control of air conditioning. Indoor temperature can be adjusted precisely and smoothly. LED headlights, electrically heated rear-view mirrors, multifunction steering wheel. The multi-media equipment can be controlled by the buttons integrated in the steering wheel.
- 左右贯通式设计, 三座椅, 二合一卧铺。车门关闭后, 隔音性达到国际重卡水平。空气悬浮减震座椅, 集成背部调节、气囊腰托、人体工程学配置; 液晶、虚拟仪表盘, 12.1寸中控大屏; 集成自动空调控制界面, 精准控温, 出风柔顺。LED前大灯, 电动电热后视镜; 多功能方向盘, 可控制车内多媒体设备。

### Carrier frame 车架

- Anti-distortion box-type welded structure using high strength steel plate, higher bearing capacity.
- 细晶粒高强度钢板焊接而成的防扭转箱形结构, 承载能力强。

### Chassis engine 底盘发动机

- Model: OM471LA.E5-2 inline six-cylinder diesel engine with watercooler and inter cooler.
- Emission standard: E5A.
- Fuel reservoir capacity: 430L.
- 型号: 奔驰OM471LA.E5-2, 直列六缸, 水冷却, 增压中冷, 柴油发动机。
- 排放标准: E5A。
- 燃料箱有效容积: 430L。

### Transmission 变速箱

- Auto-transmission, 12 forward gears and 2 reverse gears, large speed ratio range, adaptable to slope climbing and high-speed traveling.
- 自动变速箱, 变速箱有 12 个前进挡, 2 个后退挡, 速比范围大, 既可满足低速场地爬坡行驶又可满足高速行驶。

### Axle 车桥

- Kessler. Axles 1, 3, 4 are drive axles of planetary transmission with inter-wheel differential lock, and axle 3 is fitted with inter-axle differential. All axles are steered. Axles 1, 2 adopt power steering with linkage feedback, and axles 3, 4 are steered hydraulically.
- 德国 Kessler 车桥, 1、3、4 桥驱动, 所有驱动桥为行星传动带有轮间差速锁, 3 桥带有轴间差速锁。全桥转向, 1、2 桥采用杆系反馈的液压助力转向系统, 3、4 桥采用电液控制转向。

### Suspension system 悬挂系统

- All axles equipped with hydro-pneumatic suspension with hydraulic lockout, height adjustable up by 100mm and down by 100mm. Driving comfort and lateral stability is therefore guaranteed on rough terrains and conditions.
- 全部车桥悬架装置均为高度可调带液压闭锁的油气悬架装置。悬挂高度可上 100mm, 下 100mm 调节, 能适应各种恶劣工况和路面, 保证车辆行驶的平顺性和侧翻稳定性, 驾驶舒适。

### Steering 转向系统

- Six steering modes incl. on-road driving (default), all-wheel steering, crab steering, reduced swing-out steering, independent rear axle steering, independent front axle steering.
- 转向模式共六种: 公路行驶模式 (默认模式), 全轮转向模式, 蟹形模式, 无偏摆转向模式, 独立后桥转向模式, 后桥锁定转向模式。

### Tires 轮胎

- 8 tires sized 385/95 R25(14.00 R25), strong bearing capacity and durability.
- 8(轮胎数) — 轮胎规格: 385/95 R25(14.00 R25), 承载能力强, 耐用。

### Wheel formula 车轮模式

- 8 × 6 × 8.

### Outrigger 支腿

- H-type layout, four point support, two-stage outrigger beam hydraulically telescoping, outrigger jack protected by two-way holding valve.
- H型支腿4点支撑, 采用细晶粒高强度钢板材料, 支腿全液压横向伸缩。垂直油缸采用双向液压锁进行安全保护。

### Brake 制动系统

- Service brake: dual circuit, air servo on all wheels, wedge brake and double air chambers functioning on front axles.
- Parking brake: functioning at axles 3 and 4 by spring-loaded air chamber.
- Assisting brake: exhaust brake, safety assured when driving down long slopes.
- 行车制动采用双回路制动系统, 所有车轮均用空气伺服制动器, 前桥采用模式制动器+双气室, 制动能力更强。
- 驻车制动是通过气室内弹簧作用在第三、四桥上。
- 辅助制动为排气制动, 保证在下长坡时的制动安全, 保证行车的安全可靠。

### Electrical system 电气系统

- CAN BUS instrument, IP65, low power consumption of 5W. Multi-functional display system, LCD screen of adjustable contrast ratio.
- CAN总线系统, 防护等级IP65, 功率消耗小, 最大仅有 5W, 多功能的集中显示系统, LCD 液晶显示屏, 对比度可调整。

# Crane Introduction

## 整机介绍

superstructure 上车

### Operator's cab 操纵室

- Curved track sliding door, foldable front step and electric side step. The seat and armrest box can be adjusted steplessly in multi ways. Auto air conditioning system gives out airflow from various vents once pressing the virtual key. Windshield wiper covers large area, ensuing clear vision in heavy rains. All new UI is equipped. Operation is realized via touchscreen, knob and buttons.
- 变轨滑移门, 电动滑移踏板; 折叠式前踏板; 座椅、扶手箱多维度电动无极调节; 汽车级集成式硬质按键, 配置全自动空调, 多通道立体送风系统, 虚拟空调按键, 前窗分体式大面积雨刮; 全新UI界面, 触摸、按键多模式操作。

### Boom & telescoping system 臂架伸缩系统

- 6 section boom, bending resistant ellipse structure welded by high tensile steel plate. Telescoping via single cylinder with auto pinning. One double-acting cylinder controls all sections to realized variable boom lengths.
- 臂结构采用抗扭曲设计, 采用高强钢板制作, 6节椭圆型主臂。伸缩采用单缸自动插销式系统, 一个双作用油缸可以控制所有起重臂的伸缩, 达到多种臂长组合。

### Hoist 起升机构

- Main winch adopts electro-proportional variable motor for better inching mobility and operation smoothness. Stepless speed control.
- 主卷扬采用电比例变量马达, 卷扬微动性、平稳性好, 能实现无级变速。

### Luffing 变幅机构

- Dual pump confluent-flow open loop, electro-proportional control. Active luffing and passive luffing combined, realizing fast lowering at large elevation and stable lowering at small elevation.
- 双泵合流开式液压回路, 电比例控制, 动力落幅和自重落幅相结合, 可实现大角度快速落幅, 小角度稳定慢速落幅。

### Slewing 回转机构

- Single slewing motor drive.
- 单回转驱动系统, 回转平稳可靠。

### Safety equipment 安全装置

- Hydraulic system reliability is guaranteed by balance valve, relief valve, and two-way holding valve.
- Length & angle indicator and pressure sensor are equipped to show real-time operation status. Hazardous motions are cut off automatically with buzzer alarming.
- 液压系统配置液压平衡阀、溢流阀、双向液压锁等元件, 实现液压系统稳定可靠。
- 配置长度传感器、角度传感器、压力传感器, 实时显示起重机作业状态, 自动切断危险动作, 蜂鸣报警。

### Counterweight 配重

- Movable counterweight features 7 combinations: 0t, 4.5t, 6.8t, 9.3t, 10.8t, 12.8t, 15t. See variable CW combination chart. CW assembly and disassembly controlled by remote device.
- 组合式可变平衡重。0t、4.5t、6.8t、9.3t、10.8t、12.8t、15t, 共7种组合方式, 详见附件组合表, 可满足不同工况的需求, 最大限度发挥结构件性能, 可遥控拆卸及安装, 微动性好。

### Optional equipment at extra fees 选配

- Aux. winch
- Aux. jib
- 16m hydraulic (mechanical) luffing jib
- 16t, 50t, 63t hook
- 1.5m × 1.3m steel outrigger pads
- Tire pressure monitoring system
- Spark arrester
- Intake shut-off valve
- Chassis centralized lubrication system
- Rear towing hook
- Boom tip camera
- 445 or 525 tires
- Customized painting
- Other equipment available upon request.
- 副卷扬
- 鹅头臂
- 16m 液压 (机械) 变幅副臂
- 16t、50t、63t 吊钩
- 1.5m × 1.3m 钢制支腿垫板
- 胎压监测系统
- 火星灭火器
- 进气切断阀
- 下车集中润滑系统
- 后拖钩
- 应急系统
- 臂头监视系统
- 445 和 525 轮胎
- 特殊涂装
- 其他配置视需求定



# Working Conditions & Code Description

## 工况组合及工况代码说明

- T - Telescopic boom 主臂
- J - Fixed jib 固定副臂
- H - Hydraulically adjustable jib 液压变幅副臂
- A - Auxiliary jib 鹅头臂



# Operating Range - T

## 起升高度曲线 - 主臂

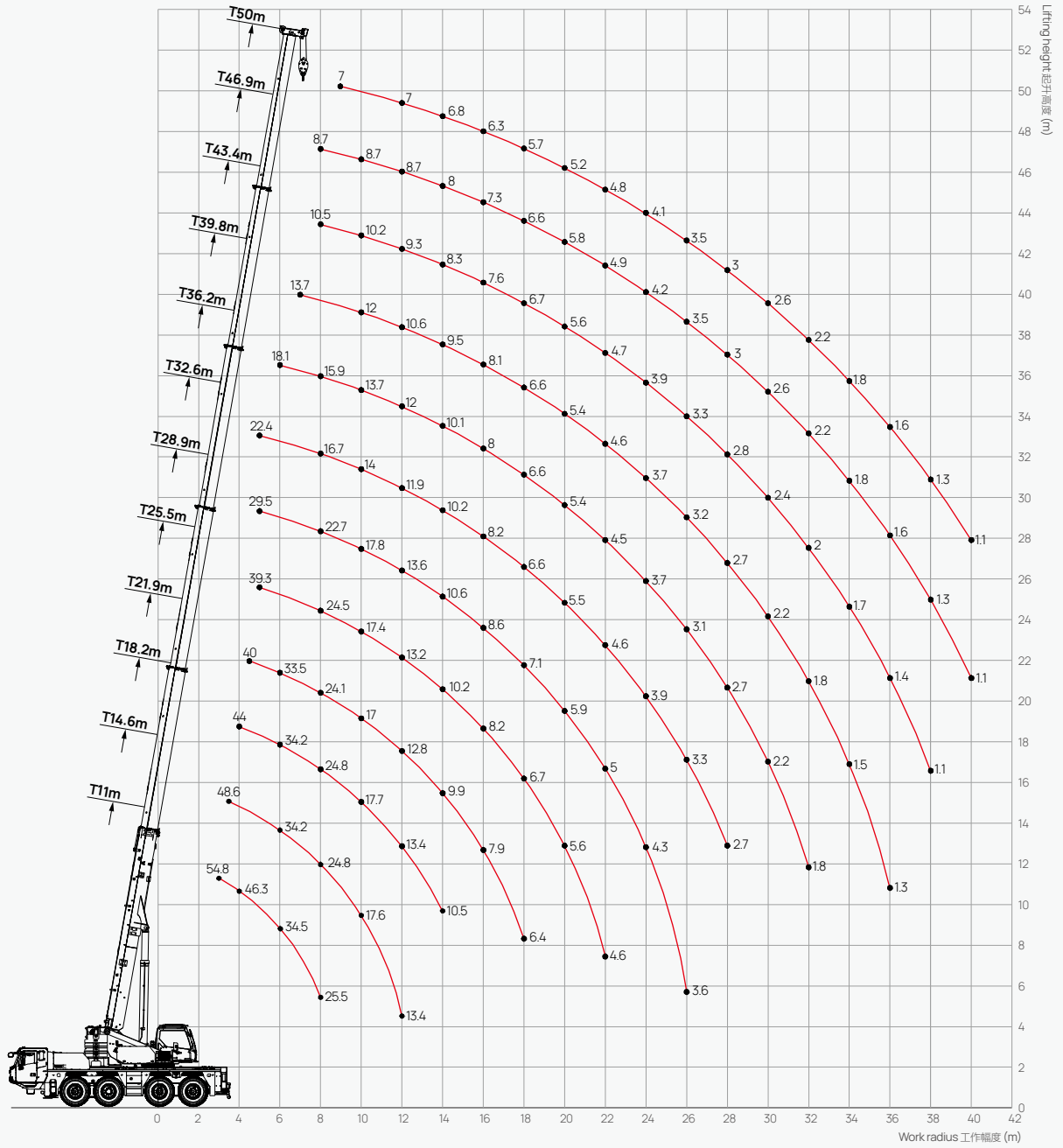







# Load Chart - Telescopic Boom

## 性能表 - 主臂

Unit: metric ton









	11	14.6	14.6	14.5	18.2	18.2	18.1	18	21.9	21.7	21.6	25.5	25.3	25.2	25.2	28.9	28.8		
3	54.8	52.4	42	25.6	51.1	46.7	29.9	18.8	49.9	31.9	22	44.3	29.6	21.7	17.2			3	
3.5	50.5	48.6	38.3	23.4	47.3	43.1	28.1	17.4	46.1	30.1	20.5	43.1	28.2	20.3	16.1	31.6	21.1	3.5	
4	46.3	45.3	35.2	22.1	44	39	26.4	16.2	42.8	28.5	19.1	41.4	26.8	19	15.1	30.6	20	4	
4.5	42.7	42.4	32.7	20.9	41.2	35.4	24.9	15.2	40	27	17.9	39.3	25.5	17.9	14.2	29.5	18.9	4.5	
5	39.6	39.3	30.6	19.8	38.7	32.9	23.5	14.3	37.5	25.7	16.9	37	24.4	16.9	13.4	28.4	18	5	
6	34.5	34.2	27.5	18	34.2	29.9	21.2	12.7	33.5	23.4	15	32.9	22.4	15.2	12.1	26.2	16.3	6	
7	30.6	30.2	24.7	16.5	30.2	27.5	19.3	11.5	29.9	21.4	13.5	29.7	20.7	13.8	10.9	24.3	14.9	7	
8	25.5	24.8	22.3	15.3	24.8	25	17.7	10.4	24.1	19.8	12.3	24.5	19.3	12.6	10	22.7	13.7	8	
9		20.7	20.9	14.3	20.7	21.4	16.4	9.6	20.1	18.4	11.3	20.4	18	11.6	9.2	20.9	12.6	9	
10		17.6	18.5	13.5	17.7	18.3	15.3	8.8	17	17.2	10.4	17.4	16.9	10.8	8.5	17.8	11.7	10	
11		15.3	16.1	13	15.3	16	14.3	8.2	14.8	16.1	9.7	15.1	15.9	10	7.9	15.5	10.9	11	
12		13.4	14.2	12.4	13.4	14.1	13.6	7.7	12.8	14.5	9	13.2	14.1	9.3	7.3	13.6	10.2	12	
14					10.5	11.1	11.7	6.9	9.9	11.5	7.9	10.2	11.1	8.2	6.5	10.6	9.1	14	
16									7.9	9.4	7	8.2	9.1	7.4	5.8	8.6	8.1	16	
18									6.4	7.8	6.3	6.7	7.5	6.6	5.2	7.1	7.4	18	
20												5.6	6.3	6.1	4.7	5.9	6.6	20	
22												4.6	5.4	5.5	4.3	5	5.6	22	
24																4.3	5	24	
26																3.6	4.3	26	
28																		28	
30																		30	
32																		32	
34																		34	
36																		36	
38																		38	
40																		40	
42																		42	
44																		44	
46																		46	
48																		48	
50																		50	
52																		52	
54																		54	
56																		56	
58																		58	
60																		60	
	13	12	10	6	12	11	7	4	11	7	5	10	7	5	4	7	5		
	2#	0	0	0	0	0	0	0	46	0	0	46	0	0	0	46	0	2#	
	3#	0	46	0	0	46	0	0	46	0	0	46	46	0	0	46	46	3#	
	4#	0	0	0	0	46	46	0	0	46	46	0	46	46	46	0	46	46	4#
	5#	0	0	46	0	0	46	46	0	0	46	46	46	46	46	92	46	46	5#
	6#	0	0	0	46	0	0	46	92	0	46	92	0	46	92	92	46	92	6#
	14.3	14.3	14.3	14.3	14.3	14.3	14.3	14.3	14.3	14.3	14.3	14.3	14.3	14.3	14.3	14.3	14.3		

# Load Chart - Telescopic Boom

## 性能表 - 主臂

Unit: metric ton



	28.8	32.6	32.4	32.4	32.4	36.2	36	36	39.8	39.8	39.6	39.6	43.4	43.3	46.9	50		
3																	3	
3.5	16.8																3.5	
4	15.9	23.6	20.4	16.9	16												4	
4.5	15.1	23.2	19.5	16.3	15.5												4.5	
5	14.3	22.4	18.6	15.6	14.9	18.8	15.9	14.7									5	
6	13	20.5	17	14.4	13.6	18.1	14.9	13.9	13.8	13.1	12.9	11.3					6	
7	11.9	18.5	15.7	13.2	12.4	17.1	13.8	12.9	13.7	12.5	12.3	10.8	10.5	10.3	8.7		7	
8	11	16.7	14.5	12.3	11.4	15.9	12.8	11.9	13.4	11.7	11.5	10.1	10.4	10	8.7	7	8	
9	10.2	15.2	13.5	11.4	10.6	14.8	12	11.1	12.8	11	10.8	9.5	10.4	9.6	8.7	7	9	
10	9.5	14	12.6	10.7	9.8	13.7	11.3	10.4	12	10.3	10.2	8.9	10.2	9.2	8.6	7	10	
11	8.8	12.8	11.8	10	9.1	12.8	10.6	9.8	11.3	9.7	9.6	8.3	9.8	8.7	8.5	7	11	
12	8.2	11.9	11.1	9.5	8.5	12	10.1	9.2	10.6	9.1	9.1	7.8	9.3	8.2	8.4	7	12	
14	7.4	10.2	9.9	8.4	7.6	10.1	9.1	8.1	9.5	8	8.1	6.9	8.3	7.3	8	6.8	14	
16	6.6	8.2	8.9	7.6	6.8	8	8.3	7.4	8.1	7.2	7.4	5.7	7.6	6.6	7.3	6.3	16	
18	6	6.6	7.3	6.9	6.1	6.6	7.5	6.6	6.6	6.5	6.7	5.5	6.7	5.9	6.6	5.7	18	
20	5.5	5.5	6.2	6.4	5.6	5.4	6.3	6.1	5.4	5.9	6.1	5	5.6	5.4	5.8	5.2	20	
22	5	4.6	5.3	5.8	5.1	4.5	5.4	5.6	4.6	5	5.3	4.6	4.7	5	4.9	4.8	22	
24	4.7	3.9	4.5	5	4.6	3.7	4.6	5	3.7	4.3	4.6	4.2	3.9	4.4	4.2	4.1	24	
26	4.2	3.3	3.8	4.4	4.3	3.1	4	4.3	3.2	3.6	3.9	3.9	3.3	3.8	3.5	3.5	26	
28		2.7	3.3	3.8	4	2.7	3.5	3.8	2.7	3.1	3.5	3.5	2.8	3.3	3	3	28	
30		2.2				2.2	3	3.3	2.2	2.7	3	3.2	2.4	2.8	2.6	2.6	30	
32						1.8	2.6	3	1.8	2.3	2.6	2.8	2	2.5	2.2	2.2	32	
34									1.5	1.9	2.3	2.4	1.7	2.1	1.8	1.8	34	
36									1.3	1.7	1.9	2.1	1.4	1.9	1.6	1.6	36	
38													1.1	1.6	1.3	1.3	38	
40													0.9	1.4	1.1	1.1	40	
42																	42	
44																	44	
46																	46	
48																	48	
50																	50	
52																	52	
54																	54	
56																	56	
58																	58	
60																	60	
	4	5	5	4	4	4	4	4	3	3	3	3	3	3	2	2		
	2#	0	92	46	0	0	92	46	0	92	46	46	0	92	46	92	100	2#
	3#	0	46	46	46	0	92	46	46	92	92	46	92	92	92	92	100	3#
	4#	46	46	46	46	92	46	46	92	92	92	92	92	92	92	92	100	4#
	5#	92	46	46	92	92	46	92	92	46	92	92	92	92	92	92	100	5#
	6#	92	46	92	92	92	46	92	92	46	46	92	92	46	92	92	100	6#
	12.8	12.8	12.8	12.8	12.8	12.8	12.8	12.8	11.1	11.1	11.1	11.1	9.9	11.1	9.9	9		

# Operating Range - TJ

## 起升高度曲线 - 副臂

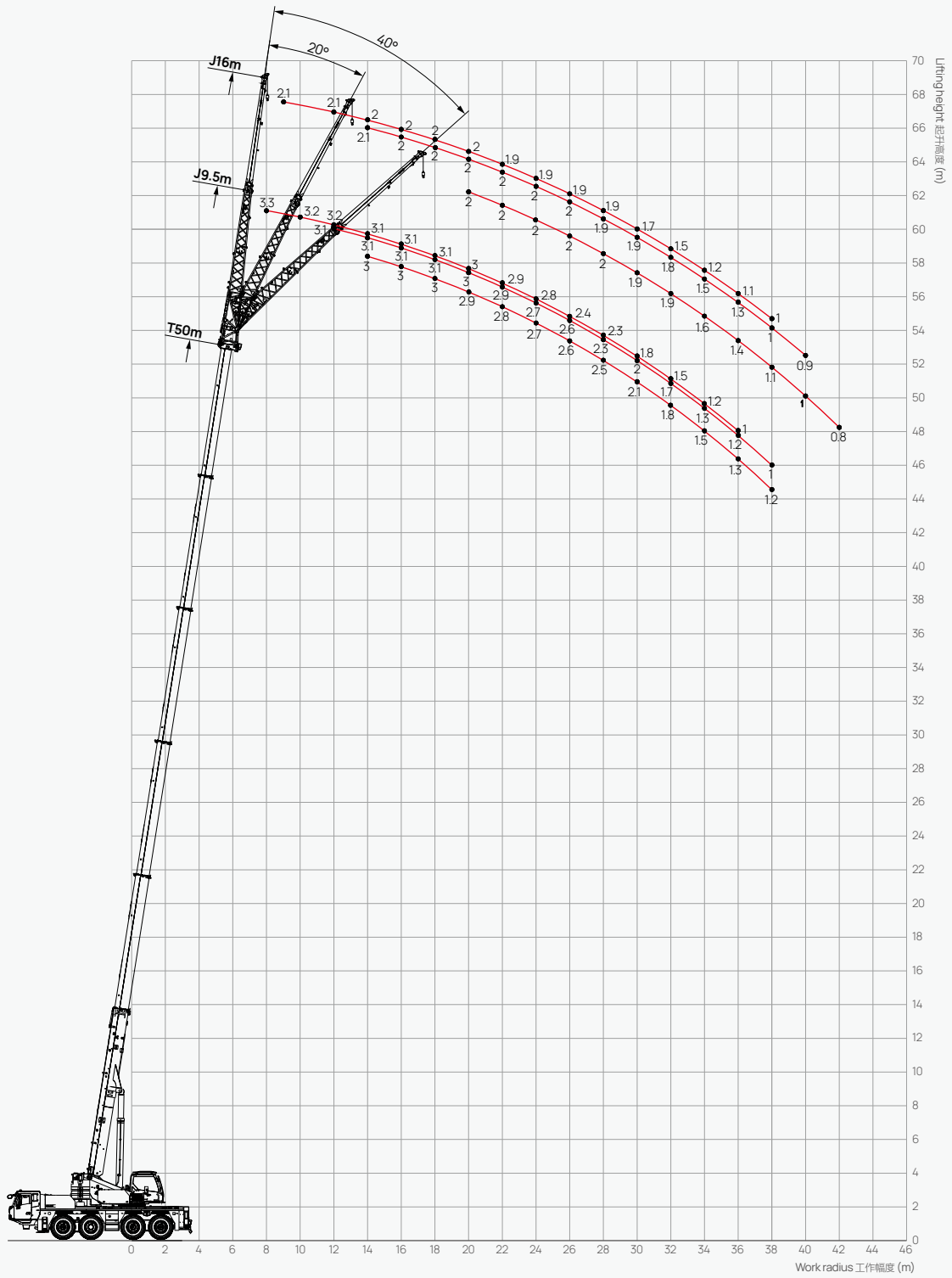

# Load Chart - Fixed Jib

## 性能表 - 副臂

Unit: metric ton

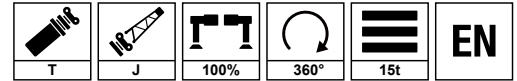

	39.8m+9.5m			43.4m+9.5m			46.9m+9.5m			50m+9.5m				
	0°	20°	40°	0°	20°	40°	0°	20°	40°	0°	20°	40°		
3													3	
3.5													3.5	
4													4	
4.5													4.5	
5	8												5	
6	7.9			6.9									6	
7	7.7			6.8			3.9						7	
8	7.5			6.6			3.9			3.3			8	
9	7.3	6.8		6.5			3.9			3.3			9	
10	7.2	6.5		6.3	6		3.8			3.2			10	
11	6.9	6.3	5.4	6.1	5.5	5.1	3.6	3.7		3.2	3.2		11	
12	6.5	6	5.2	5.8	5.3	5	3.5	3.7	3.6	3.2	3.1		12	
14	6.1	5.7	5	5.6	5.2	4.9	3.4	3.6	3.6	3.1	3.1	3	14	
16	5.6	5.5	4.7	5.3	4.9	4.6	3.3	3.6	3.5	3.1	3.1	3	16	
18	5.2	4.8	4.5	5	4.7	4.4	3.2	3.5	3.4	3.1	3.1	3	18	
20	4.7	4.5	4.3	4.3	4.5	4.2	3.1	3.4	3.3	3	3	2.9	20	
22	4.1	4.3	4.1	3.6	4	4	3	3.2	3.1	2.9	2.9	2.8	22	
24	3.4	3.7	3.9	3.1	3.4	3.8	3	3	3	2.8	2.7	2.7	24	
26	2.9	3.1	3.4	2.9	2.9	3.1	2.5	2.8	2.8	2.4	2.6	2.6	26	
28	2.4	2.6	2.8	2.6	2.6	2.8	2.1	2.3	2.5	2.2	2.3	2.5	28	
30	2	2.2	2.4	2.2	2.4	2.5	1.8	2	2.2	1.8	2	2.1	30	
32	1.9	1.8	2	1.9	2.1	2.2	1.6	1.6	1.8	1.5	1.7	1.8	32	
34	1.6	1.5	1.6	1.6	1.7	1.8	1.5	1.5	1.5	1.2	1.3	1.5	34	
36	1.3	1.3	1.4	1.4	1.4	1.5	1.3	1.3	1.3	1	1.2	1.3	36	
38	1.1	1.2		1.1	1.2	1.3	1.2	1.2	1.2		1	1.2	38	
40	0.9	1		0.9	1	1.1				1			40	
42				0.7	0.8								42	
44													44	
46													46	
48													48	
50													50	
52													52	
54													54	
56													56	
58													58	
60													60	
	2	2	2	2	2	2	1	1	1	1	1	1		
	2#	92	92	92	92	92	92	92	92	92	100	100	100	2#
	3#	92	92	92	92	92	92	92	92	92	100	100	100	3#
	4#	92	92	92	92	92	92	92	92	92	100	100	100	4#
	5#	46	46	46	92	92	92	92	92	92	100	100	100	5#
	6#	46	46	46	46	46	46	92	92	92	100	100	100	6#

# Load Chart - Fixed Jib

## 性能表 - 副臂

Unit: metric ton

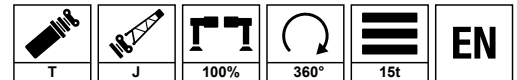

	39.8m+16m			43.4m+16m			46.9m+16m			50m+16m				
	0°	20°	40°	0°	20°	40°	0°	20°	40°	0°	20°	40°		
3													3	
3.5													3.5	
4													4	
4.5													4.5	
5													5	
6	3.8												6	
7	3.8			3.4									7	
8	3.8			3.4			2.4						8	
9	3.8			3.4			2.4			2.1			9	
10	3.8			3.3			2.4			2.1			10	
11	3.7	3.1		3.3	3		2.4			2.1			11	
12	3.7	3		3.3	2.8		2.4			2.1			12	
14	3.7	2.9		3.2	2.7		2.4	2.4		2	2.1		14	
16	3.7	2.7	2.3	3.2	2.6	2.3	2.3	2.3		2	2		16	
18	3.5	2.6	2.2	3.2	2.5	2.2	2.3	2.3	2.1	2	2		18	
20	3.4	2.5	2.2	3.1	2.5	2.2	2.3	2.3	2.1	2	2	2	20	
22	3.2	2.5	2.1	3.1	2.4	2.1	2.2	2.3	2.1	1.9	2	2	22	
24	3.1	2.4	2.1	3.1	2.3	2.1	2.2	2.3	2	1.9	2	2	24	
26	3	2.3	2.1	2.8	2.3	2.1	2.2	2.2	2	1.9	2	2	26	
28	2.7	2.2	2.1	2.4	2.2	2	2.2	2.2	2	1.9	1.9	2	28	
30	2.3	2.2	2	2.2	2	2	1.9	2.1	2	1.7	1.9	1.9	30	
32	2	2.1	2	2	1.9	2	1.6	2	2	1.5	1.8	1.9	32	
34	1.7	2	1.9	1.8	1.8	2	1.3	1.6	1.9	1.2	1.5	1.6	34	
36	1.4	1.7	1.8	1.5	1.5	1.9	1.2	1.3	1.6	1.1	1.3	1.4	36	
38	1.2	1.4	1.5	1.2	1.3	1.7	1.1	1.1	1.3	1	1	1.1	38	
40	1	1.2	1.2	1	1.2	1.4		0.9	1		0.9	1	40	
42	0.8	1	1	0.8	1	1.1		0.8	0.8			0.8	42	
44		0.8	0.9	0.6	0.8	0.9							44	
46						0.7							46	
48													48	
50													50	
52													52	
54													54	
56													56	
58													58	
60													60	
	1	1	1	1	1	1	1	1	1	1	1	1		
	2#	92	92	92	92	92	92	92	92	92	100	100	100	2#
	3#	92	92	92	92	92	92	92	92	92	100	100	100	3#
	4#	92	92	92	92	92	92	92	92	92	100	100	100	4#
	5#	46	46	46	92	92	92	92	92	92	100	100	100	5#
	6#	46	46	46	46	46	46	92	92	92	100	100	100	6#



## SANY GROUP CRANE BU

SANY Mobile Crane Industrial Park, No.168 Jinzhou Avenue, Jinzhou Development Zone, Changsha City,  
Hunan Province, P.R. China Zip 410600  
Consulting [sanycrane@sanygroup.com](mailto:sanycrane@sanygroup.com) (Crane BU) / [crd@sany.com.cn](mailto:crd@sany.com.cn) (IHQ)  
After-sales Service 0086-400 6098 318

Reminder:  
Any change in the technical parameters and configuration due to product modification or upgrade may occur without prior notice.  
The machine in the picture may include additional equipment. This brochure is for reference only, and goods in kind shall prevail.  
Copyright at SANY. No part of this brochure may be copied or used for any purpose without written approval from SANY.

© Edited in April 2024

### 三一集团起重事业部

中国湖南长沙金洲开发区金洲大道 168 号 三一汽车起重机产业园 邮编: 410600  
咨询: [sanycrane@sanygroup.com](mailto:sanycrane@sanygroup.com) (起重事业部) / [crd@sany.com.cn](mailto:crd@sany.com.cn) (国际总部)  
海外售后服务: 0086-400 6098 318

温馨提示:  
由于技术不断更新, 技术参数及配置如有更改, 恕不另行通知。图中机器可能包括附加设备, 本画册仅供参考, 以实物为准。  
版权为三一所有, 未经三一书面许可, 本画册任何内容不得被复制用于任何目的。

© 2024 年 4 月版

