



Intelligent Roadheader EBZ160i

Heading Monster



Remote control

Through the combination of wireless and wired, one-key automatic cutting is realized, and the control distance is more than 500m.



Highly intelligent

Autonomous navigation, slope tracking, pose error $\leq 0.1^\circ$. Heading angle error $\leq 0.15^\circ$.



Fault warning

Equipped with a complete sensor network, online monitoring of working conditions, early warning and alarm of faults.



Efficient cutting

Adaptive cutting technology, identify the hardness of coal and rock, and adjust the cutting feed speed independently.



High security

Electronic security system, with the function of proximity identification and alarm for personnel in dangerous areas.



3D simulation

Combination of virtual and real attitude coordinates, real-time display and control application of roadheader position.

Main technical data

Project	Parameter
Positioning cutting height (m)	2.3 ~ 5.3
Positioning cutting width (m)	3.5 ~ 5.75
Gradeability(°)	± 20
Working slope (°)	± 18
Unilateral compressive strength of Max/suitable in cutting rock	≤ 80/60
Dinting depth	247
Rotating speed of cutting head/ telescopic length(rpm/mm)	46/23/550
Loading capacity (m³/min)	3.5
Ground clearance (mm)	260
Cutting motor power (kW)	160/100
Oil pump motor power (kW)	90

Weight/Dimensional data

Project	Parameter	
Maximum non-removable size (length × width × height) (m)	body frame	3.65 × 1.16 × 1.32
	front chute of the first conveyor	3.80 × 0.59 × 0.57
	rear support frame	1.21 × 2.27 × 1.10
Maximum weight of non-removable parts (kg)	body frame	5400
Machine weight (t)	second conveyor	49

SANY HEAVY EQUIPMENT CO., LTD

Address: 16 Kaifa Road, Economic & Technological Development Zone
Shenyang Liaoning Province, P.R.China.

Postal Code: 110027

Official Website: www.sanyglobal.com

Sales Hotline | Tel: 0086-24 8931 8365 Customer Service Hotline | Tel: 0086-400 8808 318

Reminder:

Any change in the technical parameters and configuration due to product modification or upgrade may occur without prior notice. The machine in the picture may include additional equipment. This brochure is for reference only, and goods in kind shall prevail. Copyright at SANY. No part of this brochure may be copied or used for any purpose without written approval from SANY.

Cutting system

- Dual telescopic patented technology to solve the eccentric cutting load.
- Internal spray patented technology to solve industry problems.
- Flexible coupling to reduce the failure of cutting part.
- Motor box cutting to improve cutting capacity.

Electric hydraulic system

- Sensitive response and precise control.
- Energy saving and consumption reduction, real-time replenishment.
- Fault warning and precise positioning.
- Equipped with 145+145 electronically controlled pump.

Inertial navigation system

- Precise positioning of the main engine in the well.
- Autonomous navigation, automatic deviation correction.

Visual system

- Automatically crop video assist.
- 1080P HD camera, infrared fill light.
- Fully display the work scene.

Electronic control system

- Flexible operation and precise control.
- Manual, line-of-sight control, over-the-horizon control over 500 meters.

Power system

- Optimized design to achieve gradeability of ± 20° and working gradient of ± 18°
- Anti-cavitation design of pumping station output system.

Overall size

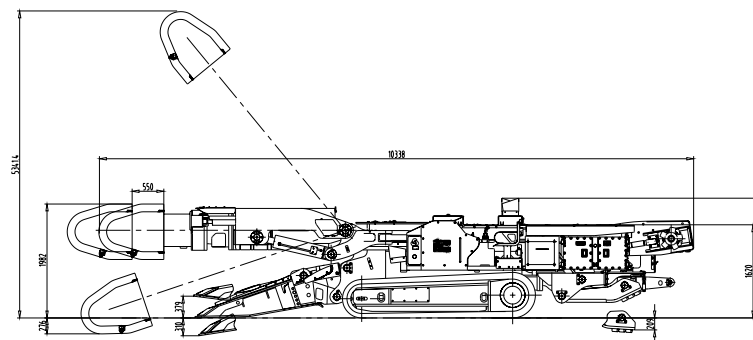

SANY



Follow our WeChat official account to learn more.